



TO BE KEPT WITH BOAT DOCUMENTS
BEI DEN SCHIFFSPAPIEREN AUFBEWAHREN
A CONSERVER AVEC LES DOCUMENTS DU BATEAU
PA ADJUNTAR A LA DOCUMENTACION DE LA EMBARCACION
BÖR FÖRVARAS I BÅTEN

Volume 10 Winch Parts Manual

LEWMAR®

CONTENTS

CONTENTS	Page
Introduction	
Service Notes	3/4/5
Spares Kit	3
Owners Service Log	25
Notes	26
Single Speed Winches	
No.'s 6, 7, 8 from April 1992	6
Two Speed Winches	
No.16 from April 1992	7
No.'s 24, 30, 40 from April 1992	8
No. 43 from April 1992	9
No. 44 from April 2002	9
Self Tailing Winches	
No. 14ST from August 2000	10
No. 16ST from April 1992	10
No. 30ST from April 1992	11
No. 40 ST from April 1992	12
No. 44ST from April 1992	13
No. 48ST from April 1992	14
No. 50ST from April 1992	15
No. 54ST from April 1992	16
No. 58ST from April 1992	17
No. 62ST from April 1992	18
No. 64ST from April 1992	19
No. 66ST from April 1992	20/21
No. 66ST-3 from April 1996	22/23
Winch Handles	
Power Grip	24
Double Turn	24
Lewmar Limited Warranty	27

INTRODUCTION

GB

Lewmar is the world's leading manufacturer of yacht winches. Our manufacturing facilities set the highest standards in quality materials and performance. Each Lewmar winch is tested to ensure that all stages in the manufacturing process conform to the Lewmar requirements of dimensional accuracy, rated strength and operating efficiency. Our winches are approved to Lloyds standards and in practice are in excess of them. Lewmar winches are constantly being tested in the latest racing competition, onboard leading ocean racers around the world and, whether racing or cruising, they are rated for their long life and performance.

However, as with any precision engineered assembly, Lewmar winches need regular maintenance to operate at peak efficiency. Without this attention, permanent damage and premature wear can result.

This manual gives complete parts details of custom winches in the Lewmar range together with service, assembly and mounting notes.

Lewmar has a worldwide network of offices and distributors who carry stocks of spare parts and spare kits. Expert advice and assistance is available for any servicing or repair problem.

GUARANTEE

Lewmar winches have been developed over many years by extensive testing aboard the world's finest ocean racers, long distance cruising yachts and match racing yachts. They are manufactured to quality standards in excess of those required by Lloyds and only the finest materials are used.

If installed, used and maintained as described in this manual they will give outstanding performance.

SERVICE NOTES

For satisfactory long term performance and product life these winches must be given the routine and full maintenance procedure described below.

Monthly – All Lewmar winches should be hosed down with fresh water then lightly oiled and greased in the separate free leaflet, 'How to service your winch'.

Two or three times during active sailing season – All Lewmar winches should be stripped, cleaned and lubricated.

At the end of each sailing season or before starting the new season –

All Lewmar winches should be completely stripped, cleaned, thoroughly checked for damage, lubricated and reassembled as detailed in this service manual.

SERVICE PROCEDURES

Dismantling – Lewmar winches are simple to dismantle and are designed for easy maintenance. The exploded view drawings show how the component parts can be removed easily from each winch.

Assembly – Winches must be assembled in the reverse sequence to the order of dismantling.

Mounting – All winches must be mounted using the correct size and type of retaining bolts. The winch must be mounted on a flat clean surface.

The hole centres for the winch retaining bolts must be marked off and drilled separately. The winch should be bedded on a light coating of sealing compound to stop leaks – too much compound gets in gears and pawls.

The winch retaining fastenings must be securely tightened (but not overtightened). The winch is self draining and care must be taken to ensure the drain holes are not blocked.

Handles – All current winches accept any standard international handle (Lewmar grey grip handle).

Full service facilities for Lewmar winches are provided at our factory, subsidiary companies, distributors and service centres worldwide. A full listing is provided at the back of this manual.

Parts pricing is subject to change. Apply to your nearest Lewmar office or distributor for current price lists.

RECOMMENDED LUBRICANTS

Grease – Lewmar grease 7010 (Lubricate Marine Lube 'A', etc.).

Oil – Light Machine Oil (3 in 1 or equivalent).

SPARES KIT

19700100	Spares Kit 6 – 43 4 x Standard small pawls and springs, 4 x gear spindle sleeves, 3 x keys, 4 x circlips.		
19700200	Spares Kit 16ST – 66ST 6 x Standard small pawls, 4 x standard large pawls, 12 x pawl springs, 6 x gear spindle sleeves, 2 x collets, 2 x circlips.	19701300	equipment, outboard engines and many other marine applications.
19700300	Spares Kit 44 – 65PB (Not applicable for 88 – 144).	19701600	Naval Jelly – Packed in handy 200ml jar. Removes tarnishing from stainless steel surfaces and protects the material.
19700401	50 – 66 6 x Standard large pawls and 12 x pawl springs.		RaceLube™ – 55ml plastic bottle. High performance winch oil. Special HD22 formula for winch pawls, springs and similar applications, where the use of grease is not advised.
19700501	6 – 48/66 6 x Standard small pawls and 12 x pawl springs.	19701500	English/German/French/Spanish/Swedish – Multi Language 'How to Service your Ocean Winch'.
19700900	Allen key set.		Ask your nearest dealer/distributor for a copy of 'How to Service your Ocean Winch' or buy:-
19701000	Geargrease™ – Packed in handy 100g plastic tube.		Winch Maintenance Pack – 100g tube of grease, 55ml HD22 oil, brush, 'How to' booklet, 10 x pawl springs.
19701100	Geargrease™ – Packed in handy 300g plastic tub. This waterproof grease contains solid activation which aids the load carrying characteristics of a winch. It is also suitable for trailer wheel bearings, steering gear, hydraulic		

INSTALLATION

EINLEITUNG • INTRODUCTION • INTRODUCCIÓN • INTRODUKTION

D

Lewmar ist Weltführer in der Herstellung von Winden für Yachten. Unsere Produktionseinrichtungen erfüllen die höchsten Ansprüche, was Werkstoffqualität und Leistung anbelangt. Jede Lewmar Winde wird eingehend geprüft, um sicherzustellen, daß alle Phasen des Herstellungsvorgangs den Lewmar Forderungen für Maßgenauigkeit, Nennfestigkeit und Handhabungseffizienz genügen. Unsere Winden sind nach der Lloyds Norm genehmigt und übertreffen diese Anforderungen oft.

Lewmar Winden werden ständig in den neuesten Wettrennen erprobt, an Bord der führenden Hochsee-Rennyachten der Welt. Ob für Wettbewerb oder Fahrten gedacht, sie werden gleichermaßen für Leistung und Haltbarkeit hochgeschätzt. Wie bei jedem Präzisionsprodukt brauchen auch Lewmar Winden regelmäßige Wartung und Pflege, damit sie weiterhin ihre Spitzenleistung erbringen können. Ohne diese Pflege kann es zu dauerhaften Schäden und vorzeitiger Abnutzung kommen. Dieses Handbuch enthält detaillierte Angaben über die Arbeitsreihenfolge und Techniken, die erforderlich sind, um jede Winde aus der Lewmar Produktreihe vollkommen zu zerlegen, zu warten und wieder zusammenzubauen. Lewmar hat ein weltumspannendes Netz von Niederlassungen und Agenturen, die Ersatzteile und Aufrüstungssätze anbieten. Fachwissen und Unterstützung ist auch dort für jedes Wartungs- oder Reparaturproblem erhältlich.

Garantie

Lewmar Winden sind über viele Jahre hinweg durch weitreichende Prüfungen auf den weltbesten Hochsee-Rennyachten, Langstreckenbooten und Wettkampfyachten entwickelt worden. Sie werden nach Qualitätsnormen gefertigt, welche die Lloyds-Anforderungen übertreffen. Nur die besten Werkstoffe werden verarbeitet. Wenn diese Produkte nach den Anweisungen dieses Handbuches installiert, eingesetzt und gewartet werden, werden sie Ihnen hervorragende Leistung bieten.

Wartungshinweise

Für zufriedenstellende Leistung und lange Nutzdauer muß diesen Winden in regelmäßigen Abständen die volle Wartungsprozedur zuteil werden, wie untenstehend beschrieben.

1. Monatlich: Alle Lewmar Winden sollten mit Frischwasser abgespült und danach leicht eingölt und geschmiert werden, wie in der getrennten Broschüre "Die Pflege Ihrer Ocean - Winde" (kostenlos erhältlich) beschrieben.
2. Zwei oder drei mal während der Segelsaison: Alle Lewmar Winden sollen zerlegt, saubergemacht und neu geschmiert werden.
3. Am Ende jeder Segelsaison oder vor Beginn der neuen Saison: Alle Lewmar Winden sollten vollständig zerlegt und saubergemacht werden, wobei auf Schäden zu achten ist. Danach schmieren und wieder zusammenbauen, wie auch in diesem Wartungshandbuch erläutert.

Auseinanderbau

Es ist leicht, Lewmar Winden zu zerlegen - sie wurden für die einfache Wartung konstruiert. Die Explosionsbilder zeigen deutlich, wie die verschiedenen Einzelteile aus jeder Winde entfernt werden.

Zusammenbau

Die Winden werden in umgekehrter Reihenfolge wieder zusammengebaut.

Einbau

Alle Winden sollten mit Halteschrauben von der richtigen Größe und Art montiert werden. Nachdem entschieden worden ist, wo die Winde genau plaziert werden soll, muß die Trommel entfernt werden, wie in der Wartungs- und Einbauanweisung beschrieben. Beachten Sie bitte, daß die Winde auf eine flache, saubere Oberfläche montiert werden muß.

Die Löcher für die Halteschrauben müssen dann angezeichnet und getrennt gebohrt werden. Die Winde sollte auf eine dünne Schicht von Dichtungsmasse gebettet werden - bei zuviel Dichtungsmasse würde etwas in das Getriebe und die Sperrklinken hineinraten. Achten Sie darauf, die Haltebefestigungen fest aber nicht übermäßig stark anzuziehen. Die Winden sind selbstentwässernd, daher sollte darauf geachtet werden, daß die Drainagelöcher nicht verstopfen.

Kurbeln

Sämtliche aktuellen Winden paßt jede international genormte Kurbel (Lewmar Kurbel mit grauem Griff).

Empfohlene Schmierstoffe

Fett - Lewmar GearGrease™ 7010 (Lubriplate Marine Lube 'A' o.ä.).
Öl - Lewmar RaceLube™ (3-in-1 oder gleichwertiges)

Kundendienst und Ersatzteile

Umfassende Unterstützung für Lewmar Winden wird in unserem Werk sowie bei den Niederlassungen, Agenturen und Service-Zentren weltweit angeboten. Die Preise von Ersatzteilen können sich ändern. Fragen Sie daher bei Ihrer nächstgelegenen Lewmar Vertretung nach den aktuellen Preislisten.

F

LEWMAR est le leader mondial en matière de winchs pour bateaux de plaisance. Nos techniques de fabrication ont établi les normes de qualité de matériaux et de performance.

Chaque winch LEWMAR est essayé afin de nous assurer que les différents stades de la fabrication ont bien respecté les normes LEWMAR en matière de précision, de résistance et d'efficacité. Nos winchs sont conformes, sinon au-delà des normes du Lloyds. Les winchs LEWMAR sont continuellement mis à l'épreuve dans les courses océaniques autour du monde. Qu'ils soient destinés à la croisière ou à la course, ils sont conçus pour être efficaces et durables. Cependant, comme tout appareil mécanique de précision, les winchs LEWMAR doivent être entretenus pour pouvoir travailler au maximum de leurs possibilités. Sans cette précaution des détériorations définitives ou une usure prématurée peuvent survenir. Ce document décrit dans le détail les phases et a manière de démonter, de nettoyer, de lubrifier et de remonter tous les winchs de a gamme LEWMAR. Un réseau mondial d'agences ou de distributeurs LEWMAR tient en stock les pièces détachées et se tient à votre disposition pour route information technique.

Fiabilité

Les winchs LEWMAR ont été développés à la suite d'essais intensifs bord des bateaux de course au large, des bateaux de grande croisière ou en match racing. Ils sont fabriqués selon des normes excédant celles requises par le Lloyds et uniquement à partir des meilleurs matériaux. S'ils sont installés, utilisés et entretenus comme il est indiqué dans ce document, ils vous donneront entière satisfaction.

Entretien

Pour obtenir de votre winch le meilleur rendement ainsi qu'une grande longévité, des entretiens de routine et des entretiens plus approfondis doivent lui être appliqués tel que décrit cidessous.

1. MENSUEL: Tous les winchs LEWMAR doivent être abondamment rincés au jet puis légèrement huilés et graissés comme il est décrit dans la brochure gratuite intitulée "Notice d'entretien de votre winch Océan".
2. DEUX OU TROIS FOIS PENDANT LA SAISON DE NAVIGATION. Tous les winchs doivent être démontés, nettoyés et lubrifiés.
3. À LA FIN DE CHAQUE SAISON DE NAVIGATION OU AVANT LA SUIVANTE.

Tous les winchs doivent être complètement démontés, vérifiés attentivement, lubrifiés et remontés tel que décrit dans cette notice.

Démontage

Les winchs LEWMAR sont faciles à démonter et sont conçus pour faciliter l'entretien. Le dessin "écorché" montre comment les composants peuvent être facilement démontés.

Remontage

Les winchs doivent être remontés dans l'ordre inverse du démontage.

Fixation

Tous les winchs doivent être fixés avec des boulons de la taille et du diamètre corrects. Une fois la position du winch déterminée, le tambour doit être enlevé tel que décrit dans la notice d'entretien afin d'avoir accès aux trous de fixation. Le winch doit être monté sur une surface plane et propre. Marquer le centre des trous pour les boulons de fixation afin de pouvoir les percer séparément. Le winch doit être monté sur un léger lit de mastic afin d'éviter les fuites au niveau des boulons. Attention! trop de mastic risque de pénétration dans les engrenages.

Les écrous de fixation doivent être bien serrés, mais sans excès. Les winchs sont conçus pour se vider seuls de leur eau. S'assurer que les anguilliers ne sont pas obstrués.

Manivelles

Tous les winchs actuels acceptent les manivelles à carré international.

Lubrifiants Conseillés

Graisse: Lewmar GearGrease™ 7010 (Lubriplate marine lube 'A', etc.)

Huile: Lewmar RaceLube™ (3 en 1 ou équivalent)

Service et Pièces

Un service complet peut être obtenu de notre usine, de nos succursales, de nos distributeurs ou de nos centres de service dans le monde entier. Les prix des pièces détachées peuvent varier. Renseignez-vous auprès de votre agence LEWMAR la plus proche.

INSTALLATION

EINLEITUNG • INTRODUCTION • INTRODUCCIÓN • INTRODUKTION

E

Lewmar es el líder mundial en producción de winches para Yates. Nuestras instalaciones de fabricación establecen los más altos estándares de calidad en materiales y prestaciones. Cada winche Lewmar es probado para asegurar que todas las etapas del proceso de fabricación cumplen los requisitos de Lewmar de exactitud dimensional, resistencia establecida y eficacia de funcionamiento. Nuestros winches están aprobados según los estándares del Lloyds y en la práctica los exceden.

Los winches Lewmar se prueban constantemente en las más nuevas regatas, a bordo de los Yates líderes en regatas oceánicas en todo el mundo y, ya sea en competición o en crucero, están calificados por su larga vida y prestaciones.

Sin embargo, como ocurre con cualquier producto de mecánica de precisión, los winches Lewmar necesitan un mantenimiento regular para funcionar con la máxima eficiencia y, sin dicho cuidado, pueden dañarse permanentemente y desgastarse prematuramente.

Este manual de los más completos detalles de los pasos a seguir y la técnica requerida para desarmar completamente, dar mantenimiento y reensamblar cada winche de la gama Lewmar.

Lewmar tiene una red mundial de oficinas y distribuidores que mantienen stock de piezas de recambio y kits de recambios. Siempre se puede obtener el consejo y asistencia de un experto para solucionar cualquier problema de mantenimiento o reparación.

Notas de servicio

Para conseguir un rendimiento satisfactorio a largo plazo y una larga duración del producto se debe dar a los winches los mantenimientos de rutina y completos que se describen a continuación:

1. Mensualmente: Todos los winches deben ser regados con agua dulce y luego someramente lubricados y engrasados tal como se describe en el folleto gratuito, "Como cuidar sus Winches"
2. Dos o tres veces durante la estación de navegación: Todos los winches Lewmar deberían ser desensamblados, limpiados y lubricados.
3. Al fin de cada estación de navegación o antes de empezar la siguiente: Todos los winches Lewmar deberían ser totalmente desensamblados, limpiados, inspeccionados para detectar daños, lubricados y reensamblados como se explica en este Manual de Mantenimiento.

Desensamblado

Los winches Lewmar son sencillos de desensamblar y se han diseñado para un fácil mantenimiento. Los dibujos de vista en explosión muestran como se pueden sacar las piezas fácilmente.

Ensamblado

Los winches se deben ensamblar siguiendo los pasos de desensamblado en orden inverso.

Montaje

Todos los winches se deben instalar usando pernos de sujeción del tipo y tamaño correctos. Una vez decidida la posición de un winche, se debe desmontar el tambor tal como se detalla en las instrucciones de mantenimiento.

El winche se debe instalar en una superficie plana y despejada.

Los centros de los pernos se deben marcar y taladrarlos habiendo separado el winche. El winche se debe asentar sobre una capa de sellador LIGERA para evitar entrada de agua - demasiado sellador se introduce en los engranajes y trinquetes.

Los pernos de fijación se deben apretar (pero no sobreapretar). Los winches son autodrenantes y se debe tener cuidado de no obstruirlos agujeros de drenaje.

Manivelas

Todos los winches actuales aceptan manivelas estándar internacionales (manivelas Lewmar de mango gris).

Lubricantes recomendados

Grasa - Lewmar GearGrease™ 7010 (Lubriplate Marine Lube "A", etc).

Aceite - Lewmar RaceLube™ (3 en 1 o equivalente)

Servicio y Recambios

Disponemos de instalaciones completas de servicio en nuestra fábrica, en nuestras Sucursales, Distribuidores y Centros de Servicio en todo el mundo. Los precios de los recambios están sujetos a cambios. Consulte la oficina de Lewmar o distribuidor más cercanos para obtener tarifas actualizadas.

S

Lewmar är världens ledande tillverkare av vinschar till nöjesbåtar. Våra tillverkningsenheter arbetar under de strängaste kvalitetskrav när det gäller material och arbete. Varje enskild vinsch provas för att säkerställa att alla steg av tillverkningsprocessen uppfyller Lewmars krav på måttnoggrannhet, hållfasthet och effektivitet. Våra vinschar är godkända enligt Lloyds standards och överstiger i praktiken motsvarande krav.

Lewmar vinschar testas kontinuerligt under kappsegling, ombord på ledande havskappseglare Jordan runt och de är kända för lång livslängd och höga prestanda, antingen det gäller kappsegling eller cruisingssegling. Precis som alla andra precisionstillverkade produkter kräver även Lewmar vinschar regelbundet underhåll för att fungera optimalt. Bristfälligt underhåll kan nämligen leda till permanenta skador och snabb förslitning. Denna instruktionsbok innehåller utförlig information om hur man tar isär, underhåller och sätter ihop samtliga vinschar i Lewmar-serien.

Lewmar har ett världsomspännande nät av kontor och återförsäljare som har reservdelar och reservdelssatser på lager. Här kan du även få experthjälp och assistans om du stöter på service- och reparationsproblem.

Säkerhet

Lewmar vinschar har utvecklats under många år i krävande tester ombord på världens bästa havskappseglare, långfärdsbåtar och match racing-båtar. De tillverkas efter strängare kvalitetskrav än Lloyds normer och endast de bästa materialerna kommer till användning.

Angående service

För att uppnå optimala egenskaper och lång livslängd måste vinscharna underhållas enligt följande:

1. VARJE MÅNAD: Alla Lewmar-vinschar för spolas av med sötvatten, oljas in sparsamt och smörjas enligt det separata häftet "Hur du servar din vinsch".
2. TVÅ ELLER TRE GÅNGER UNDER SÄSONGEN: Alla Lewmar-vinschar bör tas isär helt och hållet, rengöras och smörjas.
3. EFTER SEGLINGSSÄSONGENS SLUT ELLER FÖRE NÄSTA SÄSONG: Alla Lewmar-vinschar bör tas isär helt och hållet, rengöras, kontrolleras avseende skador, smörjas och sätts ihop enligt servicehandbokens anvisningar.

Isärtagning

Lewmar-vinschar är enkla att ta isär och utformade för enkelt underhåll. Sprängkisserna visar hur de olika delarna tas bort i tur och ordning.

Hopsättning

Hopsättning utförs i omvänd ordning jämfört med isärtagning.

Montering

Vid montering av vinschar måste fästbultar av korrekt dimension och typ användas. Börja med att bestämma var vinschen ska placeras och ta sedan bort trumman enligt underhållsanvisningarna för montering. Observera att vinschen måste monteras på en plan och ren yta. Hålen för vinschens fästbultar måste markeras och borras separat. Vinschen bör ställas på ett tunt lager tätningsmassa för att förhindra läckage - för mycket tätningsmassa kan tränga in i drev och spärmekanism. Dra åt fästbultarna ordentligt (dra dock inte åt för hårt). Eftersom vinschen är självdränerande är det viktigt att dräneringshålen inte är igensatta.

Handtag

Alla internationella standardhandtag passar till Lewmars vinschar (Lewmar-handtag med grått grepp).

Rekommenderade smörjmedel

Fett - Lewmar GearGrease™ 7010 (Lubriplate Marinfett "A", etc.).

Olja - Lewmar RaceLube™ (3-i-1 eller likvärdigt).

Service och reservdelar

Komplett serviceutrustning för Lewmar-vinschar finns vid vår fabrik, hos dotterbolag, återförsäljare och serviceställen över hela världen. Reservdelspriser kan ändras. Rekvirera en aktuell prislista från närmaste Lewmar-kontor eller återförsäljare.

No.'s 6/7/8 - 1 SPEED WINCH

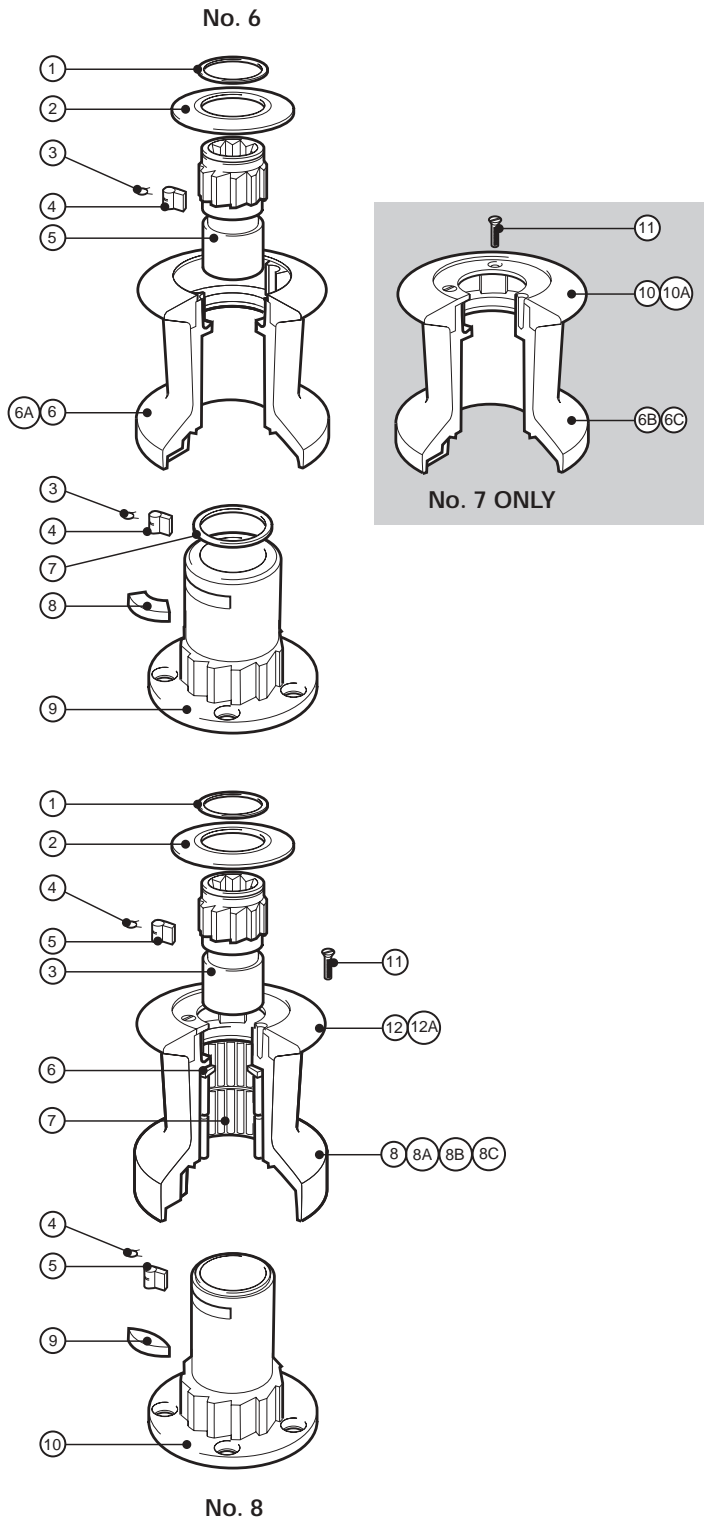

No. 6 - 1 SPEED WINCH

Item	Description	Part Number	No. Off
1	Circlip	B2075	1
2	Top Cap	45001000	1
3	Pawl Spring	1260/7	4
4	Pawl	1260/8	4
5	No 6/7 Spindle (Grey)	45001018	1
6	Drum Alloy (Black)	15000363	1
6a	Drum Alloy (Grey)	45001014	1
6b	Drum Bronze	15000660	1
6c	Drum Chrome	15006102	1
7	Washer	15006004	1
8	Key	15006005	1
9	Centre Stem	15000144	1

No 7 - 1 SPEED WINCH

1	Circlip	B2075	1
2	Top Cap	45001100	1
3	Pawl Spring	1260/7	4
4	Pawl	1260/8	4
5	No 6/7 Spindle (Grey)	45001018	1
6	Drum Alloy (Black)	45001113	1
6a	Drum Alloy (Grey)	45001114	1
6b	Drum Bronze	15000661	1
6c	Drum Chrome	15000650	1
7	Washer	15006004	1
8	Key	15010005	1
9	Centre Stem	15000143	1
10	No 7b & 7c Crown (Grey)	45001109	1
10a	Crown (Black)	45001108	1
11	M5 x 12mm Long Posidriv 7b & 7c - CSK HD Screw	15000527	3

No. 8 - 1 SPEED WINCH

1	Circlip	B2075	1
2	Top Cap	45001200	1
3	Spindle	15008003	1
4	Pawl Spring	1260/7	4
5	Pawl	1260/8	4
6	Drum Washer	15008004	1
7	Roller Bearing Assembly	15008007	2
8	Drum Alloy (Black)	45001113	1
8a	Drum Alloy (Grey)	45001114	1
8b	Drum Chrome	15000661	1
8c	Drum Bronze	15000650	1
9	Key	15008005	1
10	Centre Stem	15008001	1
11	M5 x 12mm Long Posidriv 8b & 8c - CSK HD Screw	15000527	3
12	8b & 8c - Crown (Grey)	45001109	1
12a	8b & 8c - Crown (Black)	45001108	1

No. 16 – 2 SPEED WINCH

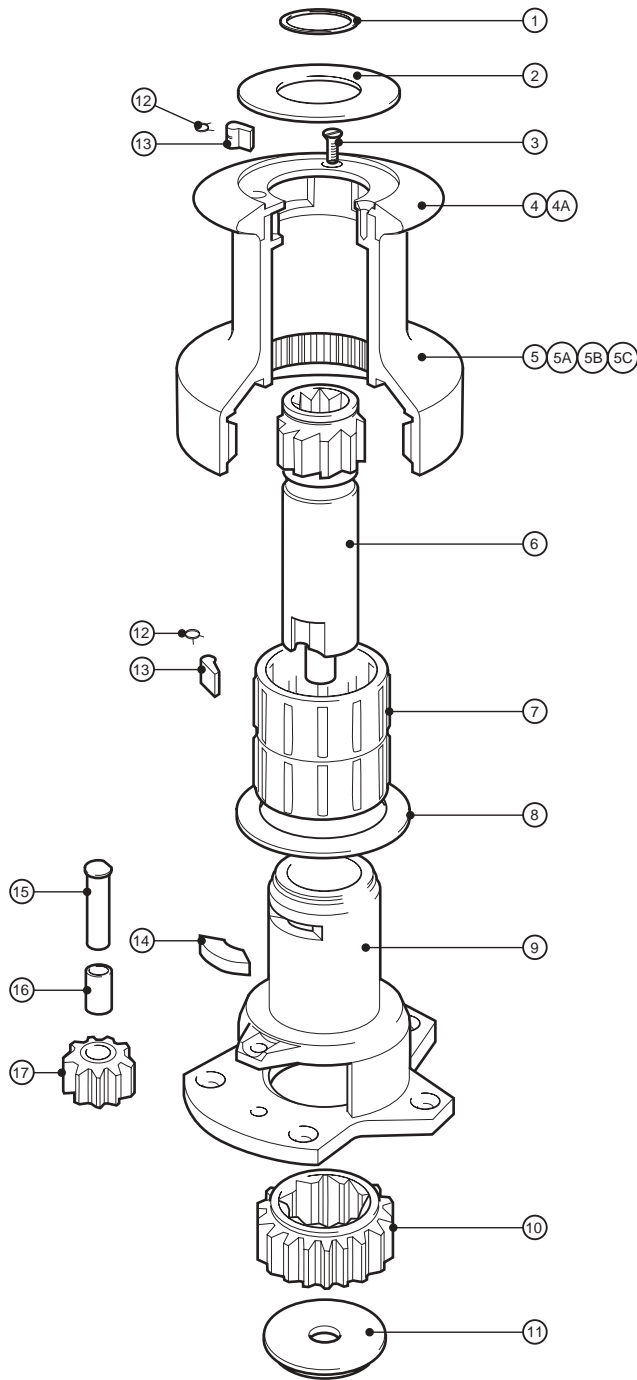

Item	Description	Part Number	No. Off
1	Circlip	B2075	1
2	Top Cap	45001300	1
3	CSK HD Posidriv Screw M5 x 12mm Long	15000527	3
4	Crown (Black)	45001108	1
4a	Crown (Grey)	45001109	1
5	Drum Alloy (Grey)	45001314	1
5a	Drum Alloy (Black)	15000454	1
5b	Drum Bronze	15000662	1
5c	Drum Chrome	15000453	1
6	Main Spindle	15000829	1
7	Roller Bearing Assembly	15008007	2
8	Drum Washer	15000466	1
9	Centre Stem (15000450)*	18000530	1
Item 9 is factory fitted with 15000377 Main Spindle Sleeve			
10	Ratchet Gear	15000464	1
11	Gear Retainer	15000461	1
12	Pawl Spring	1260/7	4
13	Pawl	1260/8	4
14	Key	15008005	1
15	Idler Spindle	15000463	1
16	Gear Spindle Sleeve	45000033	1
17	Idler Gear	15000827	1

* NOTE: Item 9 Centre Stem WITHOUT sleeve shown in (brackets)

No.'s 24/30/40 – 2 SPEED WINCH

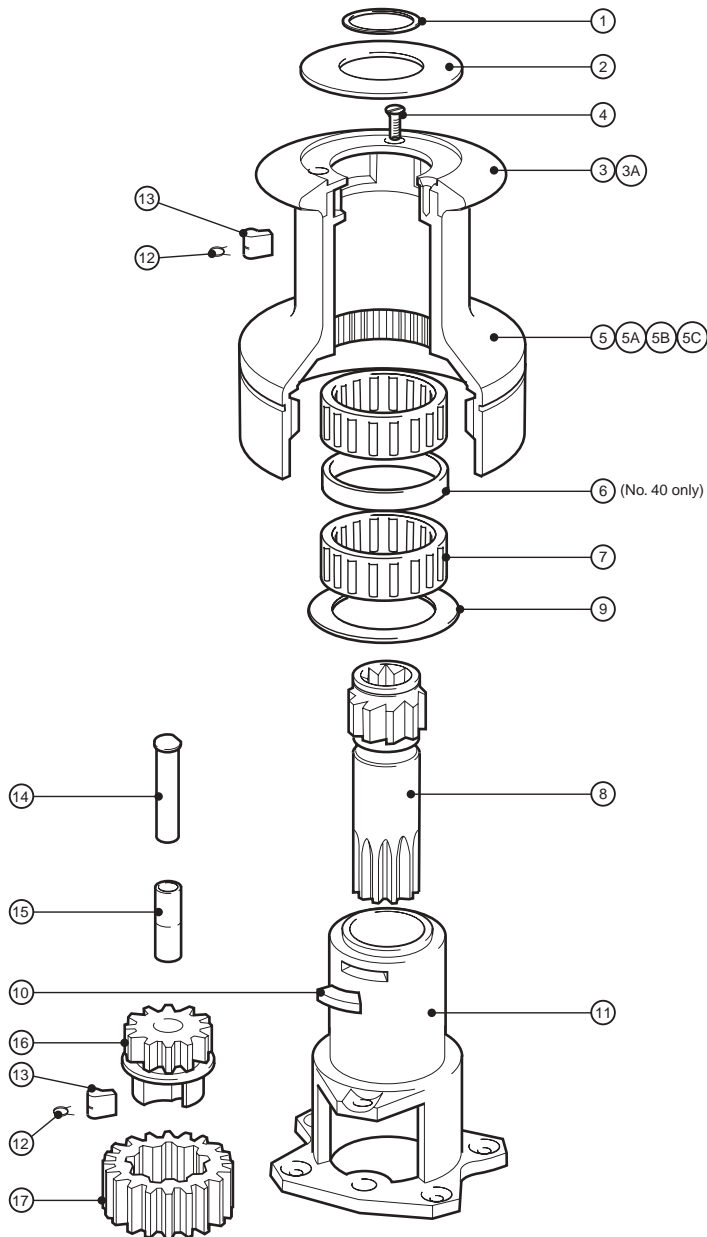

No. 24 – 2 SPEED WINCH

Item	Description	Part Number	No.off
1	Circlip	B2075	1
2	Top Cap	45001400	1
3	Crown (Grey)	45001109	1
3a	Crown (Black)	45001108	1
4	CSK HD Posidriv Screw M5 x 12mm Long	15000527	3
5	Drum Alloy (Grey)	45001414	1
5a	Drum Alloy (Black)	45000472	1
5b	Drum Bronze	15000663	1
5c	Drum Chrome	15000471	1
7	Roller Bearing Assy	15008007	2
8	Main Spindle	15000830	1
9	Drum Washer	15000376	1
10	Key	15008005	1
11	Centre Stem (15000473)*	18000531	1
Item 11 is factory fitted with 15000377 Main Spindle Sleeve			
12	Pawl Spring	1260/7	4
13	Pawl	1260/8	4
14	Gear Spindle	15000423	1
15	Gear Spindle Sleeve	15000378	2
16	Pawl Gear	15000477	1
17	Ratchet Gear	15000476	1

No. 30 – 2 SPEED WINCH

Item	Description	Part Number	No.off
1	Circlip	B2075	1
2	Top Cap	45001500	1
3	Crown (Grey)	45001509	1
3a	Crown (Black)	45001508	1
4	CSK HD Posidriv Screw M5 x 12mm Long	15000527	3
5	Drum Alloy (Grey)	45001514	1
5a	Drum Alloy (Black)	15000447	1
5b	Drum Bronze	15000664	1
5c	Drum Chrome	15000448	1
7	Roller Bearing Assembly	15008007	2
8	Main Spindle	15000830	1
9	Drum Washer	15000466	1
10	Key	15008005	1
11	Centre Stem (15000467)*	18000532	1
Item 11 is factory fitted with 15000377 Main Spindle Sleeve			
12	Pawl Spring	1260/7	4
13	Pawl	1260/8	4
14	Gear Spindle	15000385	1
15	Gear Spindle Sleeve	15000378	2
16	Pawl Gear	15000470	1
17	Ratchet Gear	15000469	1

No. 40 – 2 SPEED WINCH

Item	Description	Part Number	No.off
1	Circlip	B2075	1
2	Top Cap	45001600	1
3	Crown (Grey)	45001509	1
3a	Crown (Black)	45001508	1
4	CSK HD Posidriv Screw M5 x 12mm Long	15000527	3
5	Drum Alloy (Grey)	45001614	1
5a	Drum Alloy (Black)	15000493	1
5b	Drum Bronze	15000665	1
5c	Drum Chrome	15000492	1
6	Spacer	15000491	1
7	Roller Bearing Assembly	15008007	2
8	Main Spindle	15000831	1
9	Drum Washer	15000466	1
10	Key	15008005	1
11	Centre Stem (15000494)*	18000533	1
Item 11 is factory fitted with 15000377 Main Spindle Sleeve			
12	Pawl Spring	1260/7	4
13	Pawl	1260/8	4
14	Gear Spindle	15000486	1
15	Gear Spindle Sleeve	15000378	2
16	Pawl Gear	15000490	1
17	Ratchet Gear	15000496	1

* NOTE: Item 11 Centre Stem WITHOUT sleeve shown in (brackets)

No. 43/44 – 2 SPEED WINCH

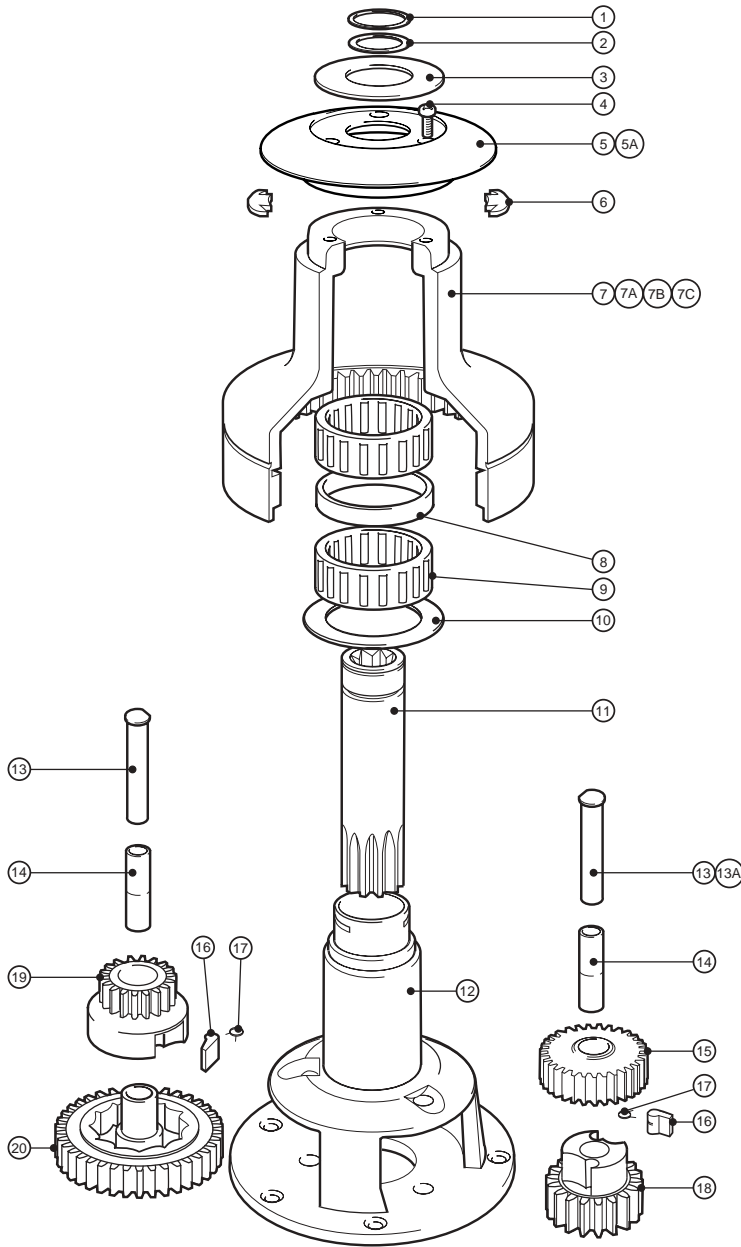

No. 43 – 2 PEED WINCH

Item	Description	Part Number	No. Off
1	Circlip	B2075	1
2	Washer	15000684	1
3	Top Cap	45001700	1
4	Pan HD Posidriv Screw M5 x 12mm Long	B0325	3
5	Crown (Grey)	45001709	1
5a	Crown (Black)	45001708	1
6	Collet	15001430	2
7	Drum Alloy (Grey)	45001714	1
7a	Drum Alloy (Black)	15000411	1
7b	Drum Bronze	15000666	1
7c	Drum Chrome	15000410	1
8	Spacer	15010008	1
9	Roller Bearing Assembly	15010007	2
10	Drum Washer	15034638	1
11	Main Spindle	15000832	1
12	Centre Stem (15001544)*	18000534	1
Item 12 is factory fitted with 15000377 Main Spindle Sleeve			
13	Gear Spindle	15000422	2
14	Gear Spindle Sleeve	15000398	4
15	Ratchet Gear	15000418	1
16	Pawl	1260/8	4
17	Pawl Spring	1260/7	4
18	Pawl Gear	15000397	1
19	Pawl Gear	15000419	1
20	Ratchet Gear	15000417	1

No. 44 – 2 PEED WINCH

Item	Description	Part Number	No. Off
1	Circlip	B2075	1
2	Washer	15000684	1
3	Top Cap	45000360	1
4	Pan HD Posidriv Screw M5 x 16mm Long	B0331	3
5	Crown (Grey)	45000362	1
5a	Crown (Black)	45000363	1
6	Collet	45000102	2
7	Drum Alloy (Grey)	45000314	1
7a	Drum Alloy (Black)	45000384	1
7b	Drum Bronze	45000316	1
7c	Drum Chrome	45000315	1
8	Spacer	15000404	1
9	Roller Bearing Assembly	15010007	2
10	Drum Washer	15044116	1
11	Main Spindle	15000832	1
12	Centre Stem (45000339)*	48044039	1
Item 12 is factory fitted with 15000377 Main Spindle Sleeve			
13	Gear Spindle	45000323	1
13a	Gear Spindle	45000324	1
14	Gear Spindle Sleeve	45000029	4
15	Ratchet Gear	45000322	1
16	Pawl	1260/8	4
17	Pawl Spring	1260/7	4
18	Pawl Gear	15000397	1
19	Pawl Gear	45000319	1
20	Ratchet Gear	45000320	1

* NOTE: Item 12 Centre Stem WITHOUT sleeve shown in (brackets)

No. L14ST/16ST - 1 SPEED SELF TAILING WINCH

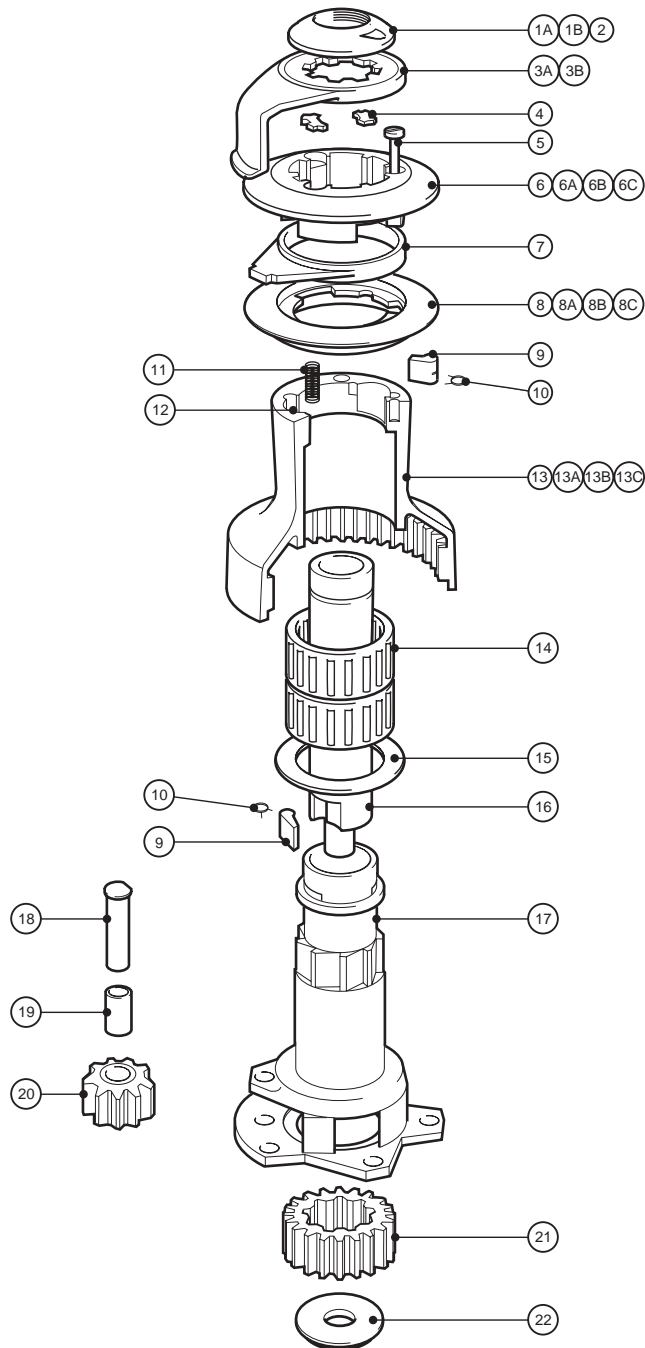

Item	Description	Part Number 16ST (L14ST)	No. Off
1a	Chrome Top Cap 16AST/16CST/16CCST	45000000	1
1b	Bronze Top Cap 16BST/16BBST	45000001	1
2	'O' Ring (Fitted in Item 1a/1b)	B6061	1
3a	Chrome Feeder Arm 16AST/16CST/16CCST (14AST/14CST)	45000003 (45000040)	1
3b	Bronze Feeder Arm 16BST/16BBST)	45000004	1
4	Collet	45000102	2
5	M5x30 S/S Posidriv Pan HD Screw	45000064	3
6	Upper Crown (Black)	45000085	1
6a	Upper Crown (Grey) 16AST/16CST/16BST	45000005	1
6b	Bronze Upper Crown Assembly 16BBST	48016000	1
6c	Chrome Upper Crown Assembly 16CCST	48016001	1
7	Stripper Ring (Grey)	45000008	1
8	Lower Crown (Black)	45000089	1
8a	Lower Crown (Grey) 16AST/16CST/16BST	45000009	1
8b	Bronze Lower Crown Assembly 16BBST	48016005	1
8c	Chrome Lower Crown Assembly 16CCST	48016006	1
9	Pawl	1260/8	5
10	Pawl Spring	1260/7	5
11	Spring	45000112	3
12	Spring Cup	45000113	3
13	Drum Alloy (Black)	45000084	1
13a	Drum Alloy 16AST (14AST)	45000014 (45000044)	1
13b	Drum Bronze 16BST/16BBST	45000016	1
13c	Drum Chrome 16CST/16CCST (14CST)	45000015 (45000045)	1
14	Roller Bearing Assembly	15008007 (48014017)	2
15	Drum Washer	15000466	1
16	Main Spindle	45000018 (45000039)	1
17	Centre Stem (45000017)* 16ST	48016017	1
17	Centre Stem (45000038)* 14ST	48014017	1
Item 17 is factory fitted with 15000377 Main Spindle Sleeve			
18	Gear Spindle	45000023	1
19	Gear Spindle Sleeve	45000033	1
20	Idler Gear	15000827	1
21	Ratchet Gear	15000464	1
22	Gear Retainer	15000461	1

NOTE:

Conversion kit for all bronze and all chrome winch:-

6b + 8b = 48016022

6c + 8c = 48016023

6b/6c/8b/8c are all assembled components NOT available separated.

* NOTE: Item 17 Centre Stem WITHOUT sleeve shown in (brackets)

No. 30ST – 2 SPEED SELF TAILING WINCH

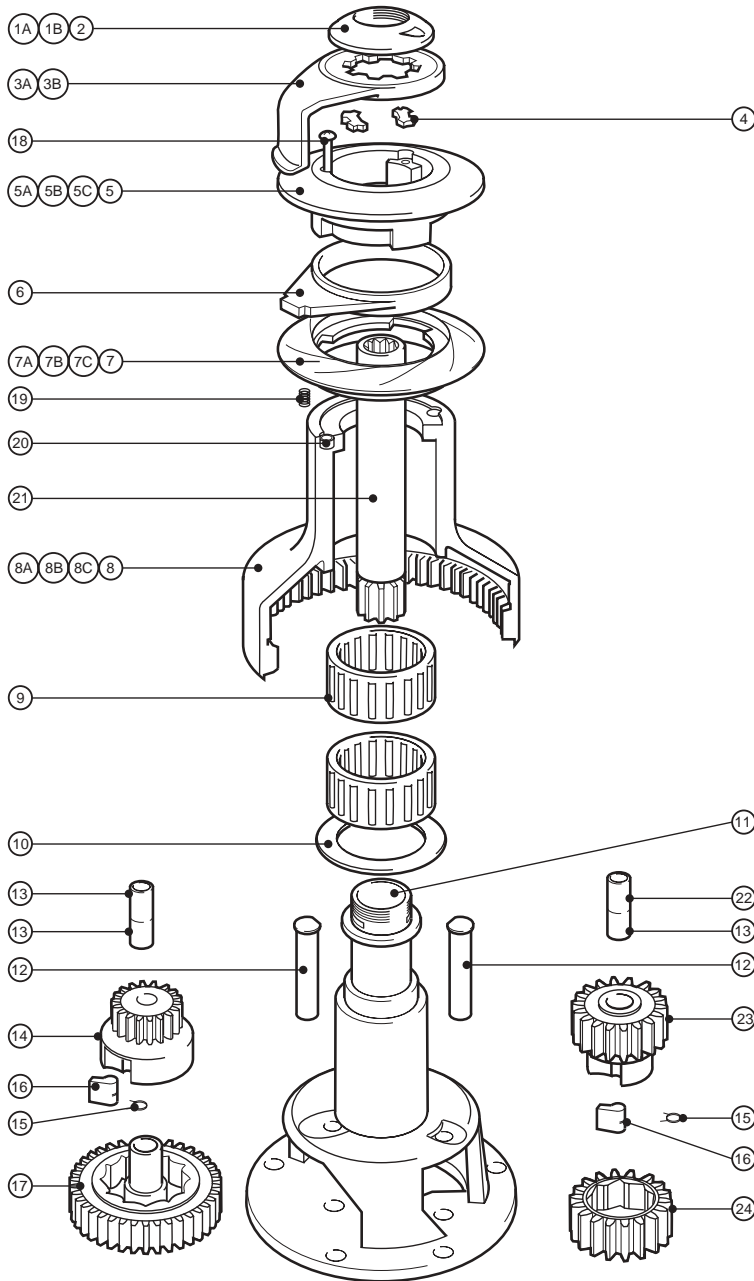

Item	Description	Part Number	No. Off
1a	Chromed Top Cap 30AST/30CST/30CCST	45000100	1
1b	Bronze Top Cap 30BST/30BBST	45000101	1
2	'O' Ring (Fitted in Item 1a/1b)	B6061	1
3a	Chrome Feeder Arm 30AST/30CST/30CCST	45000103	1
3b	Bronze Feeder Arm 30BST/30BBST	45000104	1
4	Collet	45000102	2
5	Upper Crown (Black)	45000185	1
5a	Upper Crown (Grey) 30AST/30BST/30CST	45000105	1
5b	Bronze Upper Crown Assembly 30BBST	48030000	1
5c	Chrome Upper Crown Assembly 30CCST	48030001	1
6	Stripper Ring (Grey)	45000108	1
7	Lower Crown (Black)	45000189	1
7a	Lower Crown (Grey) 30AST/30BST/30CST	45000109	1
7b	Bronze Lower Crown Assembly 30BBST	48030005	1
7c	Chrome Lower Crown Assembly 30CCST	48030006	1
8	Alloy Drum (Black)	45000184	1
8a	Alloy Drum 30AST	45000114	1
8b	Bronze Drum 30BST/30BBST	45000116	1
8c	Chrome Drum 30CST/30CCST	45000115	1
9	Roller Bearing Assembly	15008007	2
10	Drum Washer	15000466	1
11	Centre Stem (45000117)*	48030017	1
Item 11 is factory fitted with 15000377 Main Spindle Sleeve			
12	Gear Spindle	45000123	2
13	Gear Spindle Sleeve	45000029	3
14	Pawl Gear	45000119	1
15	Pawl Spring	1260/7	4
16	Pawl	1260/8	4
17	Ratchet Gear	45000120	1
18	M5x30 S/S Posidriv Pan HD Screw	B0326	3
19	Spring	45000112	6
20	Spring Cup	45000113	6
21	Main Spindle	45000118	1
22	Gear Spindle Sleeve	15000378	1
23	Pawl Gear	45000121	1
24	Ratchet Gear	45000122	1

NOTE:

Conversion kit for all bronze and all chrome winch:-

6b + 8b = 48030022

6c + 8c = 48030023

6b/6c/8b/8c are all assembled components NOT available separated.

* NOTE: Item 11 Centre Stem WITHOUT sleeve shown in (brackets)

No. 40ST – 2 SPEED SELF TAILING WINCH

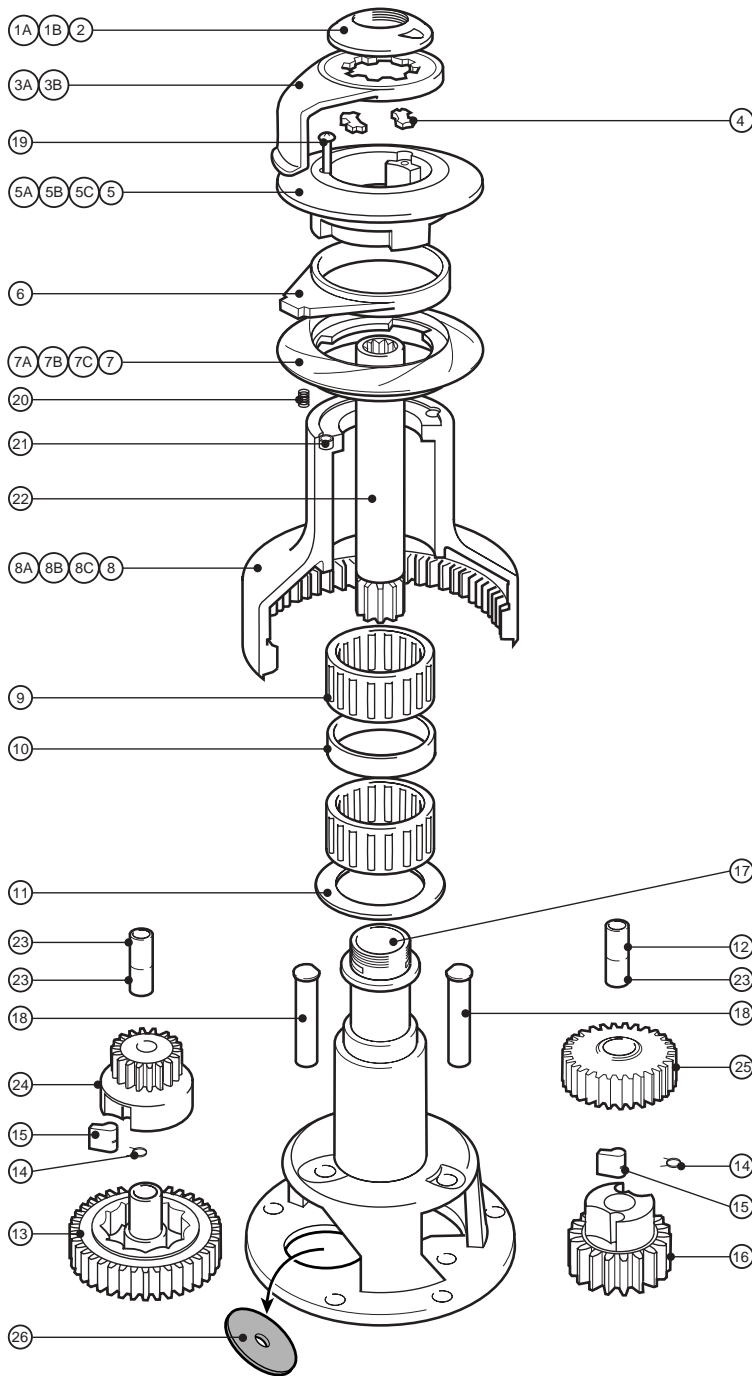

Item	Description	Part Number	No. Off
1a	Chrome Top Cap 40AST/40CST/40CCST	45000100	1
1b	Bronze Top Cap 40BST/40BBST	45000101	1
2	'O' Ring (Fitted in Item 1a/1b)	B6061	1
3a	Chrome Feeder Arm 40AST/40CST/40CCST	45000203	1
3b	Bronze Feeder Arm 40BST/40BBST	45000204	1
4	Collet	45000102	2
5	Upper Crown (Black)	45000185	1
5a	Upper Crown (Grey) 40AST/40BST/40CST	45000105	1
5b	Bronze Upper Crown Assembly 40BBST	48030000	1
5c	Chrome Upper Crown Assembly 40CCST	48030001	1
6	Stripper Ring (Grey)	45000108	1
7	Lower Crown (Black)	45000189	1
7a	Lower Crown (Grey) 40AST/40BST/40CST	45000109	1
7b	Bronze Lower Crown Assembly 40BBST	48030005	1
7c	Chrome Lower Crown Assembly 40CCST	48030006	1
8	Alloy Drum (Black)	45000284	1
8a	Alloy Drum 40AST	45000214	1
8b	Bronze Drum 40BST/40BBST	45000216	1
8c	Chrome Drum 40CST/40CCST	45000215	1
8d	Stainless Steel Drum 40SST	45000270	1
9	Roller Bearing Assembly	15008007	2
10	Bearing Spacer	15000491	1
11	Drum Washer	15000466	1
12	Gear Spindle Sleeve	15000378	1
13	Ratchet Gear	45000220	1
14	Pawl Spring	1260/7	4
15	Pawl	1260/8	4
16	Pawl Gear	45000221	1
17	Centre Stem (45000237)*	48040038	1
Item 17 is factory fitted with 15000377 Main Spindle Sleeve			
18	Gear Spindle	45000123	2
19	M5 x 35 S/S Posidriv Pan HD Screw	B0337	3
20	Spring	45000112	6
21	Spring Cup	45000113	6
22	Main Spindle	45000218	1
23	Gear Spindle Sleeve	45000029	3
24	Pawl Gear	45000119	1
25	Ratchet Gear	45000222	1
26	Stem Disc	45000238	1

NOTE:

Conversion kit for all bronze and all chrome winch:-

5b + 7b = 48030022

5c + 7c = 48030023

5b/5c/7b/7c are all assembled components NOT available separated.

* NOTE: Item 17 Centre Stem WITHOUT sleeve shown in (brackets)

No. 44ST – 2 SPEED SELF TAILING WINCH

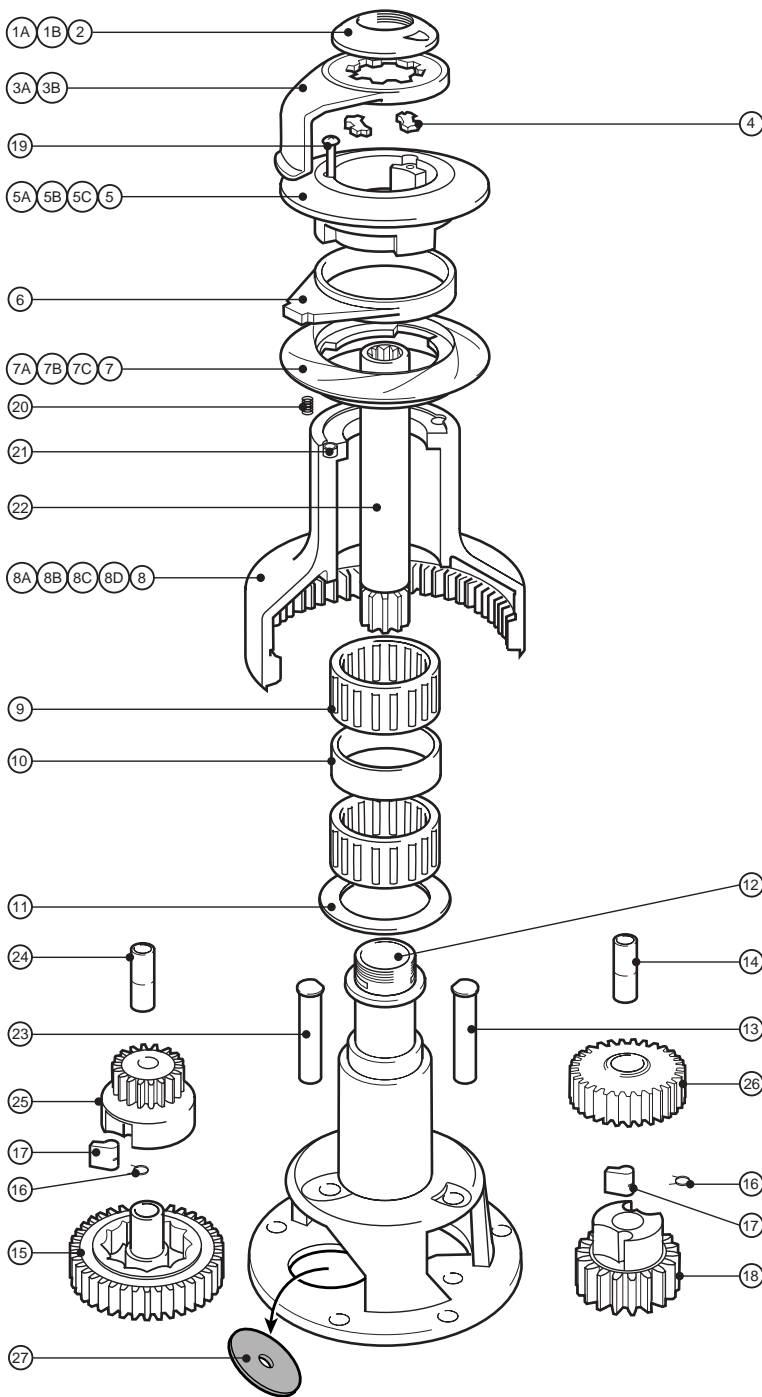

Item	Description	Part Number	No. Off
1a	Chrome Top Cap 44AST/44CST/44CCST	45000100	1
1b	Bronze Top Cap 44BST	45000101	1
2	'O' Ring (Fitted in Item 1a/1b)	B6061	1
3a	Chrome Feeder Arm 44AST/44CST/44CCST	45000303	1
3b	Bronze Feeder Arm 44BBST	45000304	1
4	Collet	45000102	2
5	Upper Crown (Black)	45000385	1
5a	Upper Crown (Grey) 44AST/44BST/44CST	45000305	1
5b	Bronze Upper Crown Assembly 44BBST	48044000	1
5c	Chrome Upper Crown Assembly 44CCST	48044001	1
6	Stripper Ring (Grey)	45000308	1
7	Lower Crown (Black)	45000389	1
7a	Lower Crown (Grey) 44AST/44BST/44CST	45000309	1
7b	Bronze Lower Crown Assembly 44BBST	48044005	1
7c	Chrome Lower Crown Assembly 44CCST	48044006	1
8	Drum Alloy (Black)	45000384	1
8a	Drum Alloy 44AST	45000314	1
8b	Drum Bronze 44BST/44BBST	45000316	1
8c	Drum Chrome 44CST/44CCST	45000315	1
8d	Drum Stainless Steel 44SST	45000370	1
9	Roller Bearing Assembly	15010007	2
10	Spacer	15000404	1
11	Drum Washer	15044116	1
12	Centre Stem (45000337)*	48044038	1
Item 12 is factory fitted with 15000377 Main Spindle Sleeve			
13	Gear Spindle	45000324	1
14	Gear Spindle Sleeve	15000398	2
15	Ratchet Gear	45000320	1
16	Pawl Spring	1260/7	4
17	Pawl	1260/8	4
18	Pawl Gear	15000397	1
19	M5 x 40 S/S Posidriv Pan HD Screw	B0327	3
20	Spring	45000112	6
21	Spring Cup	45000113	6
22	Main Spindle	45000318	1
23	Gear Spindle	45000323	1
24	Gear Spindle Sleeve	45000029	2
25	Pawl Gear	45000319	1
26	Ratchet Gear	45000322	1
27	Stem Disc	45000338	1

NOTE:

Conversion kit for all bronze and all chrome winch:-

5b + 7b = 48044022

5c + 7c = 48044023

5b/5c/7b/7c are all assembled components NOT available separated.

* NOTE: Item 12 Centre Stem WITHOUT sleeve shown in (brackets)

No. 48ST - 2 SPEED SELF TAILING WINCH

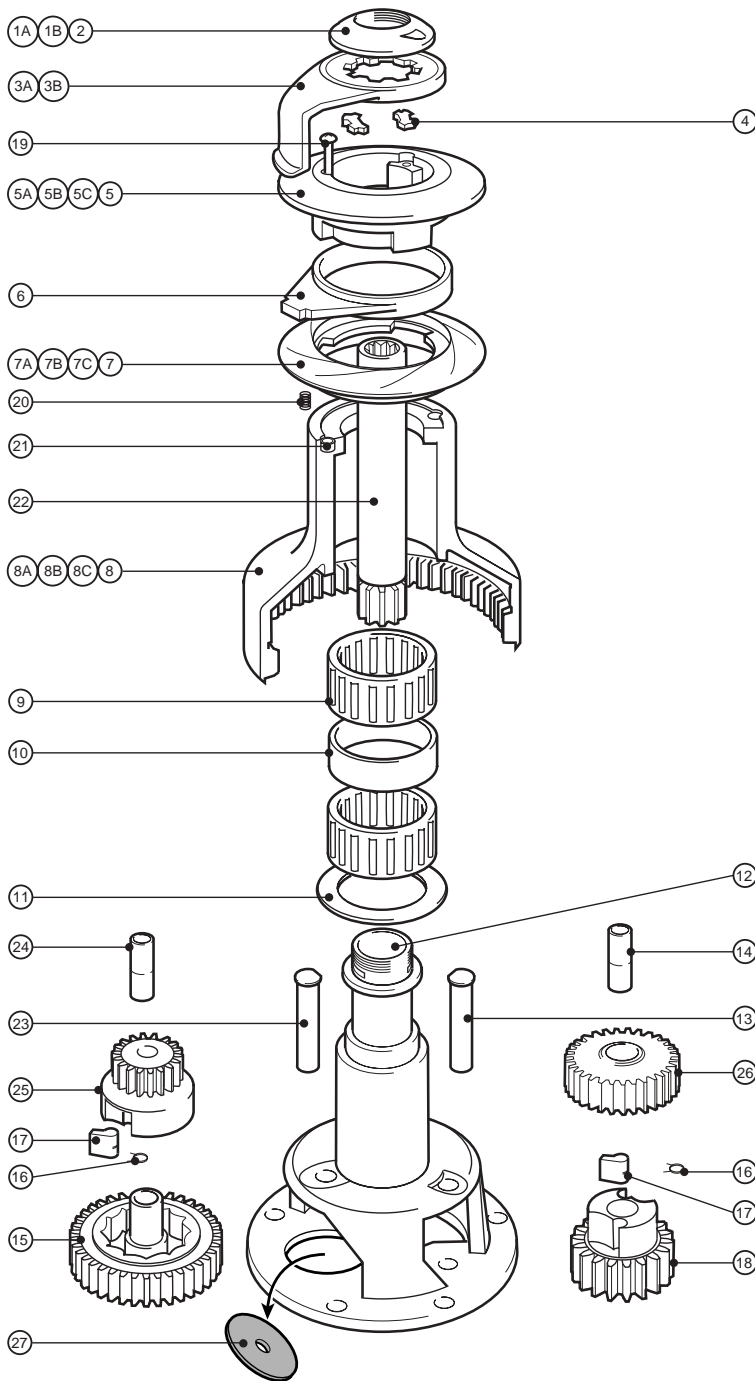

Item	Description	Part Number	No. Off
1a	Chrome Top Cap 48AST/48CST/48CCST	45000100	1
1b	Bronze Top Cap 48BST/48BBST	45000101	1
2	'O' Ring (Fitted in Item 1a/1b)	B6061	1
3a	Chrome Feeder Arm 48AST/48CST/48CCST	45000403	1
3b	Bronze Feeder Arm 48BST/48BBST	45000404	1
4	Collet	45000102	2
5	Upper Crown (Black)	45000485	1
5a	Upper Crown (Grey) 48AST/48BST/48CST	45000405	1
5b	Bronze Upper Crown Assembly 48BBST	48048000	1
5c	Chrome Upper Crown Assembly 48CCST	48048001	1
6	Stripper Ring (Grey)	45000408	1
7	Lower Crown (Black)	45000489	1
7a	Lower Crown (Grey) 48AST/48BST/48CST	45000409	1
7b	Bronze Lower Crown Assembly 48BBST	48048005	1
7c	Chrome Lower Crown Assembly 48CCST	48048006	1
8	Drum Alloy (Black)	45000484	1
8a	Drum Alloy 48AST	45000414	1
8b	Drum Bronze 48BST/48BBST	45000416	1
8c	Drum Chrome 48CST/48CCST	45000415	1
8d	Drum Stainless Steel 48SST	45000470	1
9	Roller Bearing Assembly	15044121	2
10	Spacer	15000404	1
11	Drum Washer	15044116	1
12	Centre Stem (45000437)*	48048038	1
13	Gear Spindle	45000424	1
14	Gear Spindle Sleeve	15000398	2
15	Ratchet Gear	45000420	1
16	Pawl Spring	1260/7	4
17	Pawl	1260/8	4
18	Pawl Gear	15000397	1
19	M5 x 40 S/S Posidriv Pan HD Screw	B0327	3
20	Spring	45000112	6
21	Spring Cup	45000113	6
22	Main Spindle	45000418	1
23	Gear Spindle	45000423	1
24	Gear Spindle Sleeve	45000029	2
25	Pawl Gear	45000419	1
26	Ratchet Gear	45000422	1
27	Stem Disc	45000338	1

NOTE:

Conversion kit for all bronze and all chrome winch:-

5b + 7b = 48048022

5c + 7c = 48048023

5b/5c/7b/7c are all assembled components NOT available separated.

* NOTE: Item 12 Centre Stem WITHOUT sleeve shown in (brackets)

No. 50ST – 2 SPEED SELF TAILING WINCH

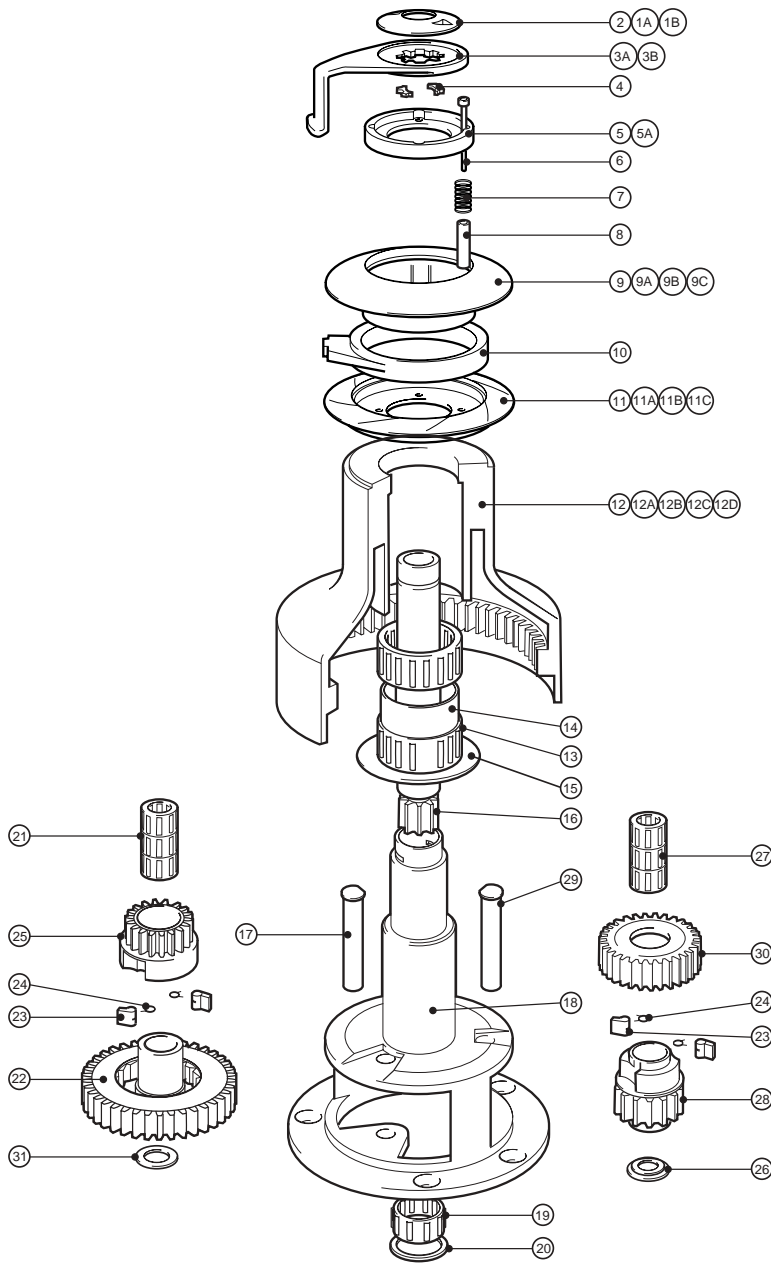

Item	Description	Part Number	No. Off
1a	Chrome Top Cap 50AST/50CST/50CCST	45000100	1
1b	Bronze Top Cap 50BST/50BBST	45000101	1
2	'O' Ring (Fitted in Item 1a/1b)	B6061	1
3a	Chrome Feeder Arm 50AST/50CST/50CCST	45000503	1
3b	Bronze Feeder Arm 50BST/50BBST	45000504	1
4	Collet	45000102	2
5	Spring Retainer (Black)	45000595	1
5a	Spring Retainer (Grey)	45000525	1
6	M6x50 Skt Hd Cap Screw	B0746	4
7	Spring	45000512	4
8	Spacer	45000513	4
9	Upper Crown (Black)	45000585	1
9a	Upper Crown (Grey) 50AST/50BST/50CST	45000505	1
9b	Bronze Upper Crown Assembly 50BBST	48050000	1
9c	Chrome Upper Crown Assembly 50CCST	48050001	1
10	Stripper Ring (Grey)	45000508	1
11	Lower Crown (Black)	45000589	1
11a	Lower Crown (Grey) 50AST/50BST/50CST	45000509	1
11b	Bronze Lower Crown Assembly 50BBST	48050005	1
11c	Chrome Lower Crown Assembly 50CCST	48050006	1
12	Drum Alloy (Black)	45000584	1
12a	Drum Alloy 50AST	45000514	1
12b	Drum Bronze 50BST/50BBST	45000516	1
12c	Drum Chrome 50CST/50CCST	45000515	1
12d	Drum Stainless Steel 50SST	45000570	1
13	Roller Bearing Assembly	15044121	2
14	Bearing Spacer	15042012	1
15	Drum Washer	45000534	1
16	Main Spindle	45000518	1
17	Gear Spindle	45000523	1
18	Centre Stem	45000517	1
19	Roller Bearing Assembly (Fitted in Item 18)	15000019	1
20	Circlip (Fitted in Item 18)	B2092	1
21	Roller Bearing Assembly	1300/SA2	3
22	Ratchet Gear	45000520	1
23	Pawl	1264/8	4
24	Pawl Spring	1260/7	4
25	Pawl Gear	45000519	1
26	Flanged Washer	15000646	1
27	Rolling Bearing Assembly	15000017	3
28	Pawl Gear	45000521	1
29	Gear Spindle	45000524	1
30	Ratchet Gear	45000522	1
31	Washer	15000981	1

NOTE:

Conversion kit for all bronze and all chrome winch:-

9b + 11b = 48050022

9c + 11c = 48050023

9b/9c/11b/11c are all assembled components NOT available separated.

No. 54ST – 2 SPEED SELF TAILING WINCH

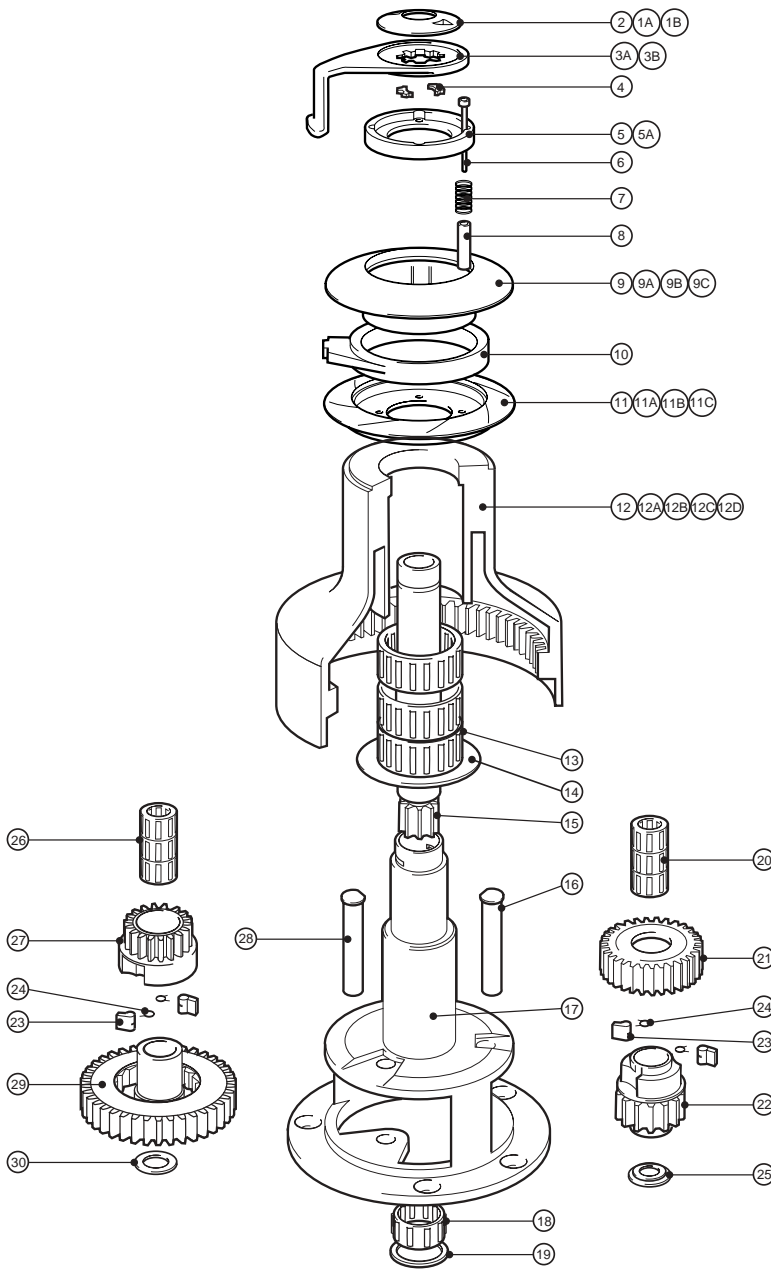

Item	Description	Part Number	No. Off
1a	Chrome Top Cap 54AST/54CST/54CCST	45000100	1
1b	Bronze Top Cap 54BST/54BBST	45000101	1
2	'O' Ring (Fitted in Item 1a/1b)	B6061	1
3a	Chrome Feeder Arm 54AST/54CST/54CCST	45000603	1
3b	Bronze Feeder Arm 54BST/54BBST	45000604	1
4	Collet	45000102	2
5	Spring Retainer (Black)	45000595	1
5a	Spring Retainer (Grey)	45000525	1
6	M6 x 50 Skt Hd Cap Screw	B0746	4
7	Spring	45000512	4
8	Spacer	45000513	4
9	Upper Crown Assembly (Black)	45000585	1
9a	Upper Crown (Grey) 54AST/54BST/54CST	45000505	1
9b	Bronze Upper Crown Assembly 54BBST	48054000	1
9c	Chrome Upper Crown Assembly 54CCST	48054001	1
10	Stripper Ring (Grey)	45000508	1
11	Lower Crown (Black)	45000589	1
11a	Lower Crown (Grey) 54AST/54BST/54CST	45000509	1
11b	Bronze Lower Crown Assembly 54BBST	48054005	1
11c	Chrome Lower Crown Assembly 54CCST	48054006	1
12	Drum Alloy (Black)	45000684	1
12a	Drum Alloy 54AST	45000614	1
12b	Drum Bronze 54BST/54BBST	45000616	1
12c	Drum Chrome 54CST/54CCST	45000615	1
12d	Drum Stainless Steel 54SST	45000670	1
13	Roller Bearing Assembly	15044121	3
14	Drum Washer	45000534	1
15	Main Spindle	45000618	1
16	Gear Spindle	45000624	1
17	Centre Stem	45000617	1
18	Roller Bearing Assembly (Fitted in Item 17)	15000019	1
19	Circlip (Fitted in Item 17)	B2092	1
20	Roller Bearing Assembly	15000017	3
21	Ratchet Gear	45000522	1
22	Pawl Gear	45000621	1
23	Pawl	1264/8	4
24	Pawl Spring	1260/7	4
25	Flanged Washer	45000646	1
26	Rolling Bearing Assembly	1300/SA2	3
27	Pawl Gear	45000519	1
28	Gear Spindle	45000523	1
29	Ratchet Gear	45000520	1
30	Washer	15000981	1

NOTE:

Conversion kit for all bronze and all chrome winch:-

9b + 11b = 48050022

9c + 11c = 48050023

9b/9c/11b/11c are all assembled components NOT available separated.

No. 58ST – 2 SPEED SELF TAILING WINCH

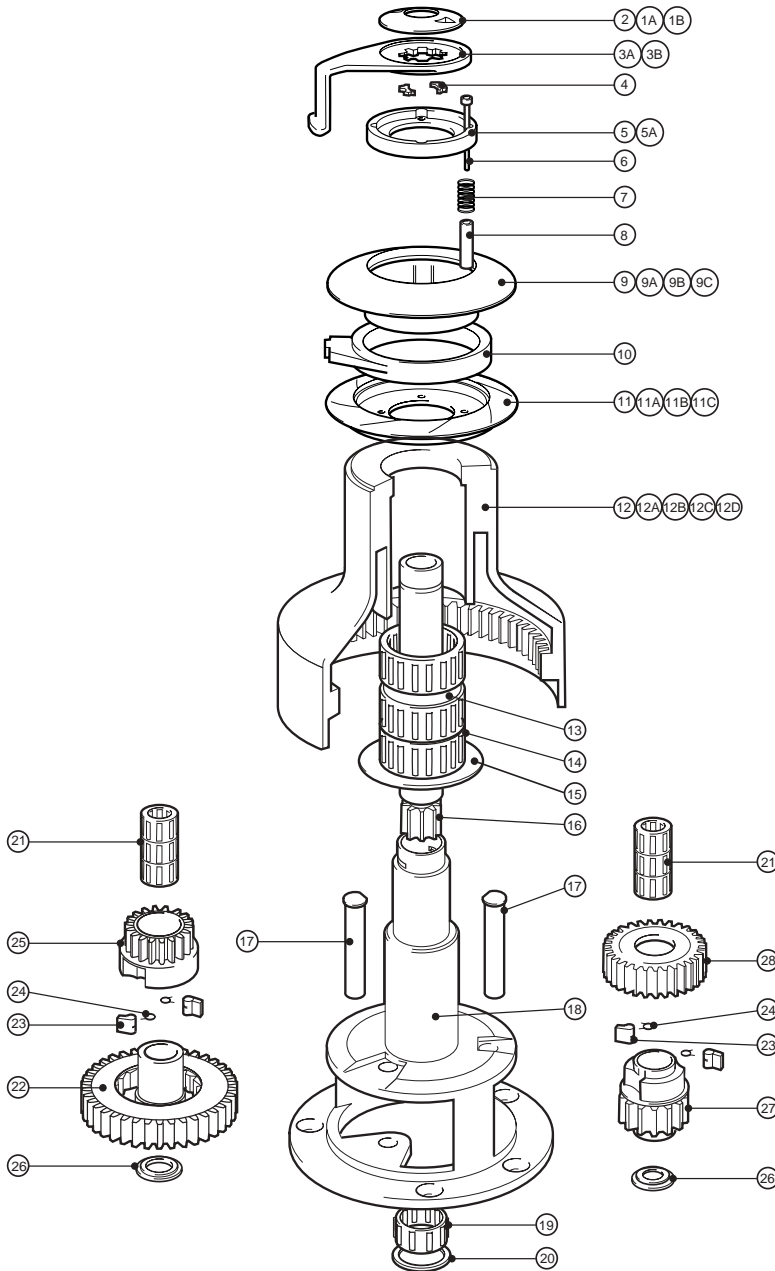

Item	Description	Part Number	No. Off
1a	Chrome Top Cap 58AST/58CST/58CCST	45000700	1
1b	Bronze Top Cap 58BST/58BBST	45000701	1
2	'O' Ring (Fitted in Item 1a/1b)	B6061	1
3a	Chrome Feeder Arm 58AST/58CST/58CCST	45000703	1
3b	Bronze Feeder Arm 58BST/58BBST	45000704	1
4	Collet	45000102	2
5	Spring Retainer (Black)	45000795	1
5a	Spring Retainer (Grey)	45000725	1
6	M6 x 55 Skt Hd Cap Screw	B0756	4
7	Spring	45000512	4
8	Spacer	45000713	4
9	Upper Crown (Black)	45000785	1
9a	Upper Crown (Grey) 58AST/58BST/58CST	45000705	1
9b	Bronze Upper Crown Assembly 58BBST	48058000	1
9c	Chrome Upper Crown Assembly 58CCST	48058001	1
10	Stripper Ring (Grey)	45000708	1
11	Lower Crown (Black)	45000789	1
11a	Lower Crown (Grey) 58AST/58BST/58CST	45000709	1
11b	Bronze Lower Crown Assembly 58BBST	48058005	1
11c	Chrome Lower Crown Assembly 58CCST	48058006	1
12	Drum Alloy (Black)	45000784	1
12a	Drum Alloy 58AST	45000714	1
12b	Drum Bronze 58BST/58BBST	45000716	1
12c	Drum Chrome 58CST/58CCST	45000715	1
12d	Drum Stainless Steel	45000770	1
13	Spacer	15065115	1
14	Roller Bearing Assembly	15044121	3
15	Drum Washer	45000534	1
16	Main Spindle	45000718	1
17	Gear Spindle	45000624	2
18	Centre Stem	45000717	1
19	Roller Bearing Assembly (Fitted in Item 18)	15000019	1
20	Circlip (Fitted in Item 18)	B2092	1
21	Roller Bearing Assembly	15000017	6
22	Ratchet Gear	45000720	1
23	Pawl	1264/8	4
24	Pawl	1260/7	4
25	Pawl Gear	45000719	1
26	Flanged Washer	15000646	2
27	Pawl Gear	45000721	1
28	Ratchet Gear	45000722	1

NOTE:

Conversion kit for all bronze and all chrome winch:-

9b + 11b = 48058022

9c + 11c = 48058023

9b/9c/11b/11c are all assembled components NOT available separated.

No. 62ST – 1 SPEED SELF TAILING WINCH

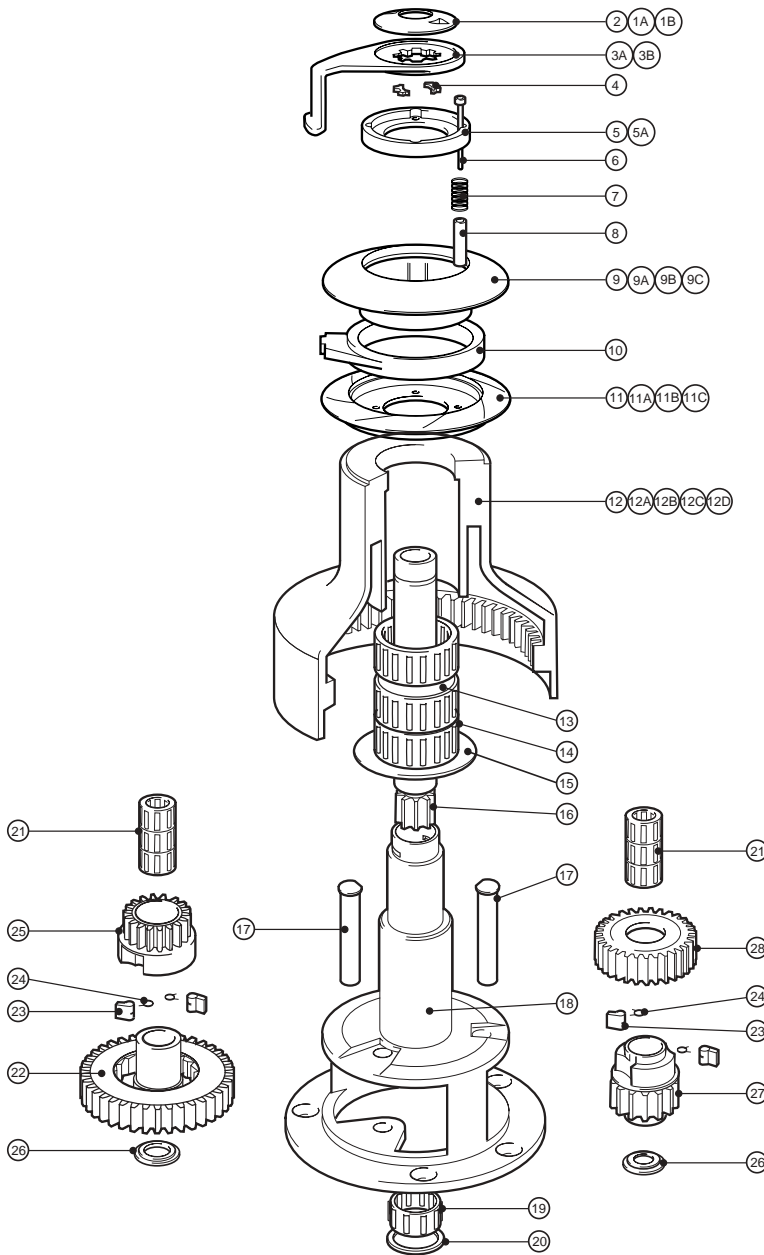

Item	Description	Part Number	No. Off
1a	Chrome Top Cap 62AST/62CST/62CCST	45000700	1
1b	Bronze Top Cap 62BST/62BBST	45000701	1
2	'O' Ring (Fitted in Item 1a/1b)	B6061	1
3a	Chrome Feeder Arm 62AST/62CST/62CCST	45000803	1
3b	Bronze Feeder Arm 62BST/62BBST	45000804	1
4	Collet	45000102	2
5	Spring Retainer (Black)	45000795	1
5a	Spring Retainer (Grey)	45000725	1
6	M6x55 Skt Hd Cap Screw	B0756	4
7	Spring	45000512	4
8	Spacer	45000713	4
9	Upper Crown (Black)	45000785	1
9a	Upper Crown (Grey) 62AST/62BST/62CST	45000705	1
9b	Bronze Upper Crown Assembly 62BBST	48058000	1
9c	Chrome Upper Crown Assembly 62CCST	48058001	1
10	Stripper Ring (Grey)	45000708	1
11	Lower Crown (Black)	45000789	1
11a	Lower Crown (Grey) 62AST/62BST/62CST	45000709	1
11b	Bronze Lower Crown Assembly 62BBST	48058005	1
11c	Chrome Lower Crown Assembly 62CCST	48058006	1
12	Drum Alloy (Black)	45000884	1
12a	Drum Alloy 62AST	45000814	1
12b	Drum Bronze 62BST/62BBST	45000816	1
12c	Drum Chrome 62CST/62CCST	45000815	1
12d	Drum Stainless Steel	45000870	1
13	Spacer	15000404	1
14	Roller Bearing Assembly	15044121	3
15	Drum Washer	45000534	1
16	Main Spindle	45000818	1
17	Gear Spindle	45000624	2
18	Centre Stem	45000817	1
19	Roller Bearing Assembly (Fitted in Item 18)	15000019	1
20	Circlip (Fitted in Item 18)	B2092	1
21	Roller Bearing Assembly	15000017	6
22	Ratchet Gear	45000720	1
22a	Ratchet Gear	45000851	1
23	Pawl	1264/8	4
24	Pawl Spring	1260/7	4
25	Pawl Gear	45000719	1
26	Flanged Washer	15000646	2
27	Pawl Gear	45000821	1
28	Ratchet Gear	45000722	1

NOTE:

Conversion kit for all bronze and all chrome winch:-

9b + 11b = 48058022

9c + 11c = 48058023

9b/9c/11b/11c are all assembled components NOT available separated.

No. 64ST – 2 SPEED SELF TAILING WINCH

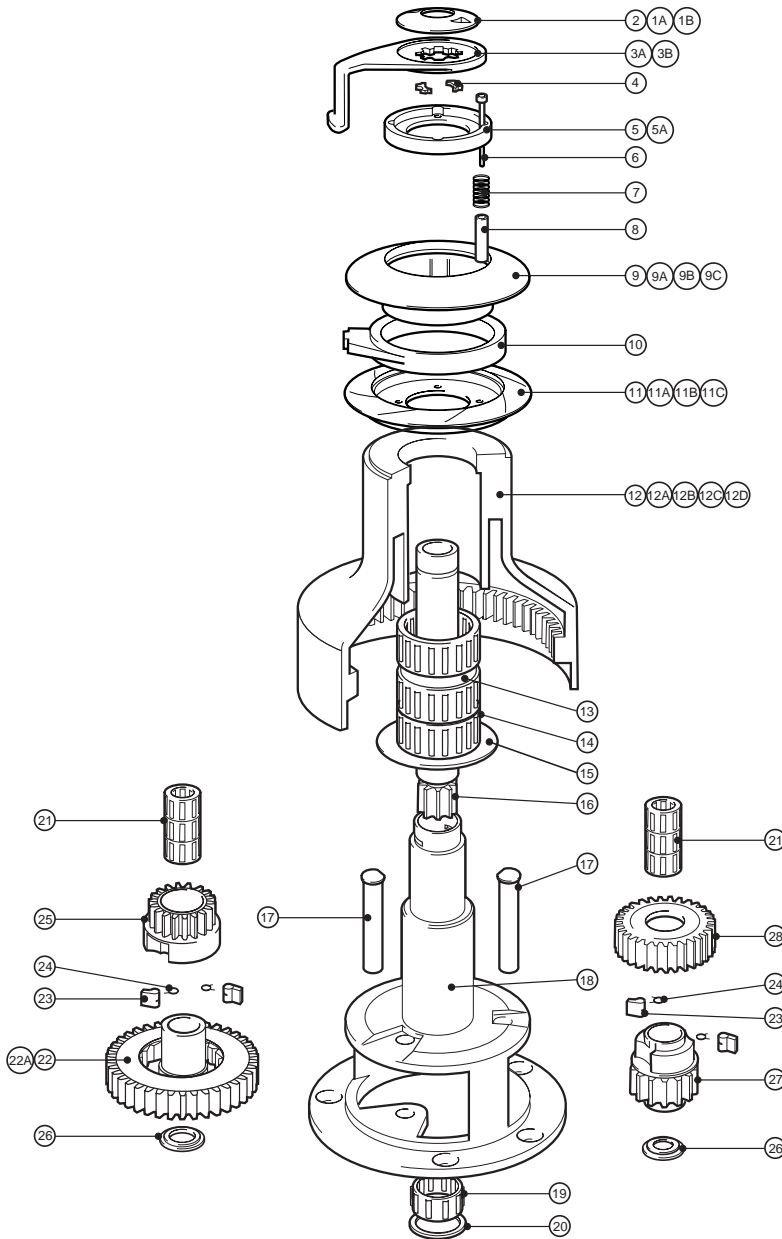

Item	Description	Part Number	No. Off
1a	Chrome Top Cap 64AST/64CST/64CCST	45000700	1
1b	Bronze Top Cap 64BST/64BBST	45000701	1
2	'O' Ring (Fitted in Item 1a/1b)	B6061	1
3a	Chrome Feeder Arm 64AST/64CST/64CCST	45000858	1
3b	Bronze Feeder Arm 64BST/64BBST	45000859	1
4	Collet	45000102	2
5	Spring Retainer (Black)	45000795	1
5a	Spring Retainer (Grey)	45000725	1
6	M6 x 55 Skt Hd Cap Screw	B0756	4
7	Spring	45000512	4
8	Spacer	45000713	4
9	Upper Crown (Black)	45000785	1
9a	Upper Crown (Grey) 64AST/64BST/64CST	45000705	1
9b	Bronze Upper Crown Assembly 64BBST	48058000	1
9c	Chrome Upper Crown Assembly 64CCST	48058001	1
10	Stripper Ring (Grey)	45000708	1
11	Lower Crown (Black)	45000789	1
11a	Lower Crown (Grey) 64AST/64BST/64CST	45000709	1
11b	Bronze Lower Crown Assembly 64BBST	48058005	1
11c	Chrome Lower Crown Assembly 64CCST	48058006	1
12	Drum Alloy (Black) 64AST	45000854	1
12a	Drum Alloy (Grey) 64AST	45000853	1
12b	Drum Bronze 64BST/64BBST	45000855	1
12c	Drum Chrome 64CST/64CCST	45000852	1
12d	Drum Stainless Steel 64SST	45000856	1
13	Spacer	15000404	1
14	Roller Bearing Assembly	15044121	3
15	Drum Washer	45000534	1
16	Main Spindle	45000818	1
17	Gear Spindle	45000624	2
18	Centre Stem	45000850	1
19	Roller Bearing Assembly (Fitted in Item 18)	15000019	1
20	Circlip (Fitted in Item 18)	B2092	1
21	Roller Bearing Assembly	15000017	6
22	Ratchet Gear	45000851	1
23	Pawl 1264/8	1264/8	4
24	Pawl Spring 1260/7	1260/7	4
25	Pawl Gear	45000719	1
26	Flanged Washer	45000646	2
27	Pawl Gear	45000821	1
28	Ratchet Gear	45000722	1

NOTE:

Conversion kit for all bronze and all chrome winch:-

9b + 11b = 48058022

9c + 11c = 48058023

9b/9c/11b/11c are all assembled components NOT available separated.

No. 66ST - 2 SPEED SELF TAILING WINCH

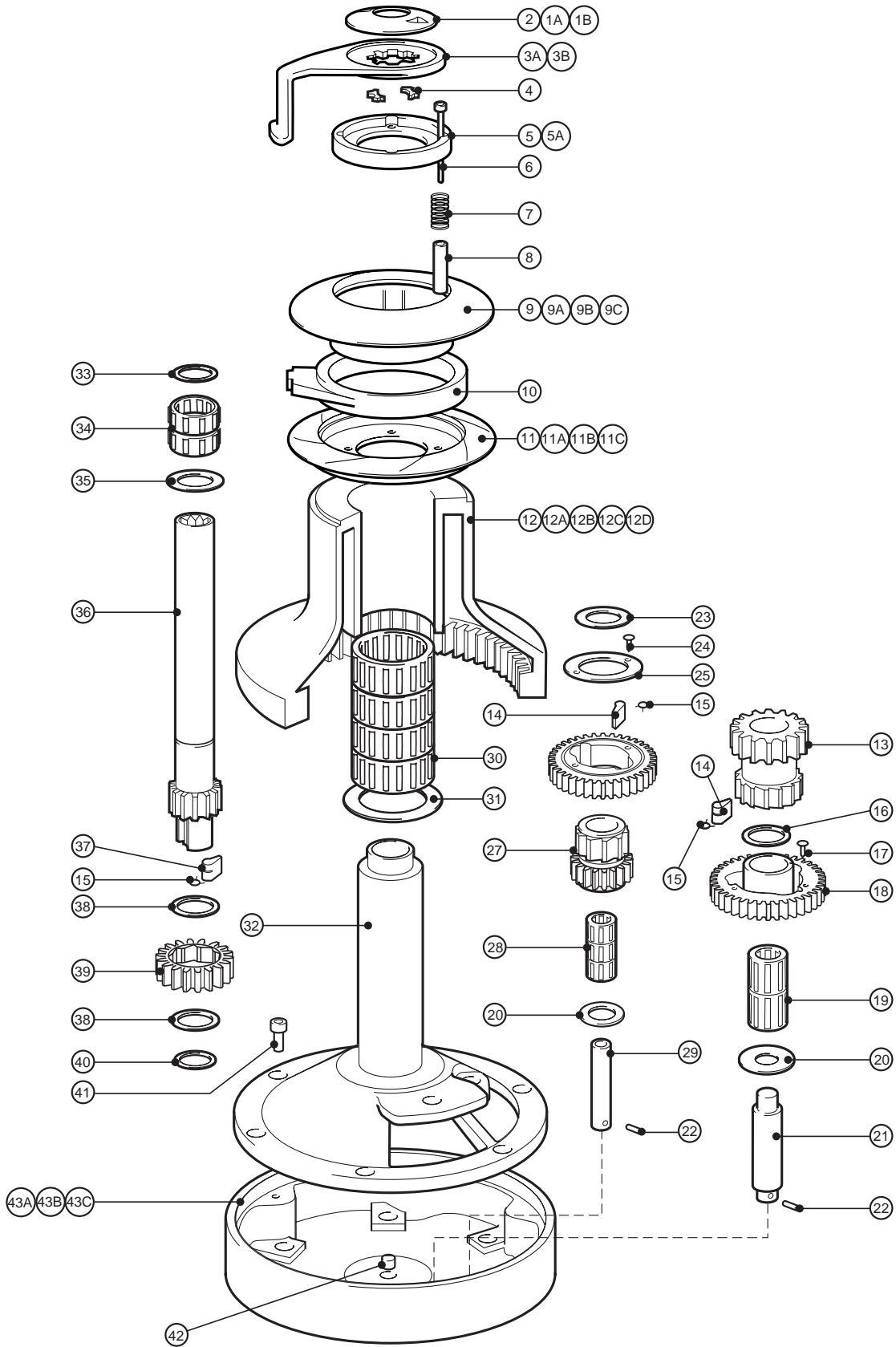

No. 66ST – 2 SPEED SELF TAILING WINCH

Item	Description	Part Number	No. Off
1a	Chrome Top Cap 66AST/66CST/66CCST	45000700	1
1b	Bronze Top Cap 66BST/66BBST	45000701	1
2	'O' Ring (Fitted in Item 1a/1b)	B6061	1
3a	Chrome Feeder Arm 66AST/66CST/66CCST	45000903	1
3b	Bronze Feeder Arm 66BST/66BBST	45000904	1
4	Collet	45000102	2
5	Spring Retainer (Black)	45000995	1
5a	Spring Retainer (Grey)	45000925	1
6	M6 x 65 S/S Skt Hd Cap Screw	B0841	5
7	Spring	45000912	5
8	Spacer	45000913	5
9	Upper Crown (Black)	45000985	1
9a	Upper Crown (Grey) 66AST/66BST/66CST	45000905	1
9b	Bronze Upper Crown Assembly 66BBST	48066000	1
9c	Chrome Upper Crown Assembly 66CCST	48066001	1
10	Stripper Ring (Grey)	45000908	1
11	Lower Crown (Black)	45000989	1
11a	Lower Crown (Grey) 66AST/66BST/66CST	45000909	1
11b	Bronze Lower Crown Assembly 66BBST	48066005	1
11c	Chrome Lower Crown Assembly 66CCST	48066006	1
12	Drum Alloy (Black)	45000984	1
12a	Drum Alloy 66AST	45000914	1
12b	Drum Bronze 66BST/66BBST	45000916	1
12c	Drum Chrome 66CST/66CCST	45000915	1
12d	Drum Stainless Steel 66SST	48066013	1
13	Ratchet Gear	45000920	1

Item	Description	Part Number	No. Off
14	Pawl	1264/8	5
15	Pawl Spring	1260/7	7
16	Washer	45000965	1
17	Fir Tree Retainer	B2233	3
18	Pawl Gear	45000919	1
19	Roller Bearing Assembly	15000018	2
20	Washer	15000247	2
21	Gear Spindle	15000239	1
22	3/16" x 3/4" Spirol Pin	B1501	2
23	Washer	15000719	1
24	M5 x 12 S/S Csk Hd Posidriv Screw	B0543	2
25	Retainer	15000023	1
26	Pawl Gear	45000922	1
27	Ratchet Gear	45000921	1
28	Roller Bearing Assembly	15000017	3
29	Gear Spindle	15001587	1
30	Roller Bearing Assembly	15044121	4
31	Drum Washer	15000287	1
32	Centre Stem	45000917	1
33	Circlip	B2086	1
34	Roller Bearing Assembly	15000019	2
35	Washer	15000024	1
36	Main Spindle	45000918	1
37	Pawl	1260/8	2
38	Spacer	15000303	2
39	Ratchet Gear	45000926	1
40	Circlip	B2075	1
41	M10 x 20 S/S Skt Hd Cap Screw	B0691	6
42	Buffer	15000723	1
43a	Base (Grey) 66AST/66CST	45000930	1
43b	Base (Chrome) 66CCST	45000931	1
43c	Base (Bronze) 66BST/66BBST	45000932	1

NOTE:

- When converting to all bronze, base 43a should be changed to 43c
- When converting to all chrome, base 43a should be changed to 43b

Conversion kit for all bronze and all chrome winch:-

9b + 11b = 48066022

9c + 11c = 48066023

9b/9c/11b/11c are all assembled components NOT available separated.

No. 66ST - 3 SPEED SELF TAILING WINCH

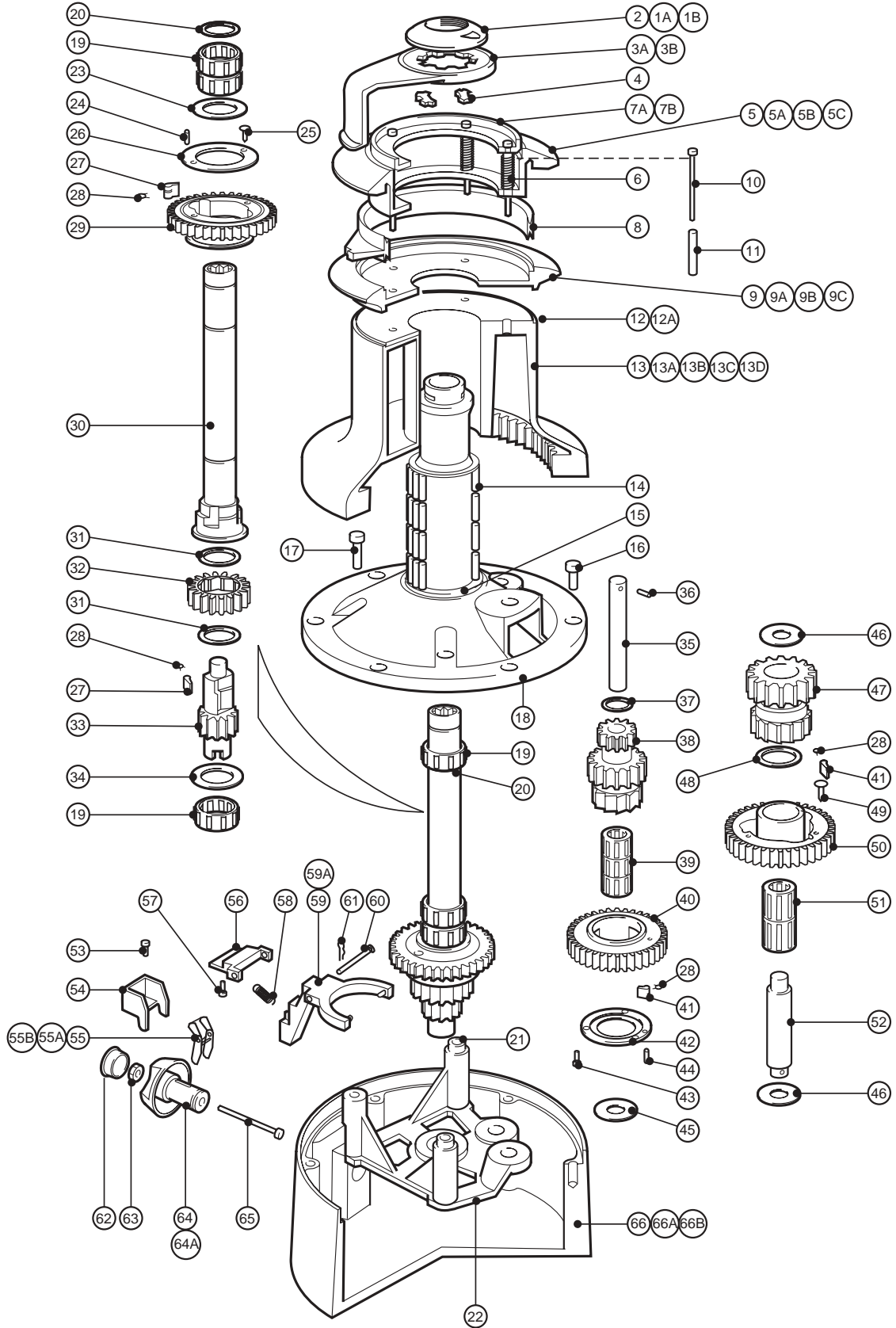

No. 66ST – 3 SPEED SELF TAILING WINCH

Item	Description	Part Number	No. Off
1a	Chrome Top Cap 66AST/66CST/66CCST	45000700	1
1b	Bronze Top Cap 66BST/66BBST	45000701	1
2	'O' Ring (Fitted in Item 1a/1b)	B6061	1
3a	Chrome Feeder Arm 66AST/66CST/66CCST	45000903	1
3b	Bronze Feeder Arm 66BST/66BBS	45000904	1
4	Collet	45000102	2
5	Upper Crown (Black)	45000985	1
5a	Upper Crown (Grey) 66AST/66BST/66CST	45000905	1
5b	Bronze Upper Crown Assembly 66BBST	48066000	1
5c	Chrome Upper Crown Assembly 66CCST	48066001	1
6	Spring	45000912	5
7	Spring Retainer (Black)	45000995	1
7a	Spring Retainer (Grey)	45000925	1
8	Stripper Ring (Grey)	45000908	1
9	Lower Crown (Black)	45000989	1
9a	Lower Crown (Grey) 66AST/66BST/66CST	45000909	1
9b	Bronze Lower Crown Assembly 66BBST	48066005	1
9c	Chrome Lower Crown Assembly 66CCST	48066006	1
10	M6 x 65 S/S Skt Hd Cap Screw	B0841	5
11	Spacer	45000913	5
12	Support Spacer	45000938	1
12a	Grommet	B3880	1
13	Drum Alloy (Black)	45000984	1
13a	Drum Alloy 66AST	45000914	1
13b	Drum Bronze 66BST/66BBST	45000916	1
13c	Drum Chrome 66CST/66CCST	45000915	1
13d	Drum Stainless Steel 66SST	48066013	1
14	Bearing	15044121	4
15	Washer	15000287	1
16	M10 x 20 Skt Hd Cap Screw	B0691	6
17	M8 x 35 Skt Hd Cap Screw	B0760	3
18	Centre Stem	45002017	1
19	Bearing	15000019	4
20	Circlip	B2086	2
21	Hollow Dowel	15065111	2
22	Bridge Piece	45002063	1
23	Washer	15000024	1
24	Dowel	15001188	1
25	M5 x 12 Posi Csk Hd Screw	B0543	2
26	Retaining Plate	15001318	1
27	Super Pawl	15000094	4
28	Spring	1260/7	10

Item	Description	Part Number	No. Off
29	Pawl Gear	45002066	1
30	3spd n/p Main Spindle	48000002	1
31	Spacer	15000022	2
32	Ratchet Gear	15000242	1
33	Spindle External	15000033	1
34	Washer	15000024	1
35	Gear Spindle	15000026	1
36	Pin	B1501	1
37	Washer	15001272	1
38	Idler Gear	45002021	1
39	Bearing	15000017	3
40	Pawl Gear	45002022	1
41	Super Pawl	15000301	6
42	Retaining Plate	15001317	1
43	M5 x 12 Pozl Csk Hd Screw	B0543	3
44	Dowel	15001188	1
45	Washer	15000247	1
46	Washer	15000247	2
47	Output Gear	45002020	1
48	Washer	15000246	1
49	Fir Tree Retainer	B2233	3
50	Pawl Gear	45002019	1
51	Bearing	15000018	2
52	Gear Spindle	15000035	1
53	Location Screw	15001276	1
54	Push Button Housing	15000203	1
55	Spring Extension	15000212	1
55a	Toggle Lever	15000204	1
55b	Toggle Arm	15000209	1
56	Bracket	15000042	1
57	M6 x 12 Skt Hd Screw	B0678	2
58	Fork Spring	15000077	1
59	Fork	15000041	1
59a	Fork Pins	15000047	2
60	Fork Spindle	15000046	1
61	Clip	15000158	1
62	Plug	15006010	1
63	M6 Standard Hex Hd Nut	B1024	1
64	Push Button	45002067	1
64a	Indicator Insert	B2234	1
65	Plunger	15001313	1
66	Base (Grey) 3 speed	45002137	1
66a	Base (Bronze) 3 speed	45002139	1
66d	Base (Chrome) 3 speed	45002138	1

NOTE:

- When converting to all bronze, base 66 should be changed to 66a
- When converting to all chrome, base 66 should be changed to 66b

Conversion kit for all bronze and all chrome winch:-

9b + 11b = 48066022

9c + 11c = 48066023

9b/9c/11b/11c are all assembled components NOT available separated.

REGULAR TURN, POWER GRIP TURNS AND LOCK SPARES

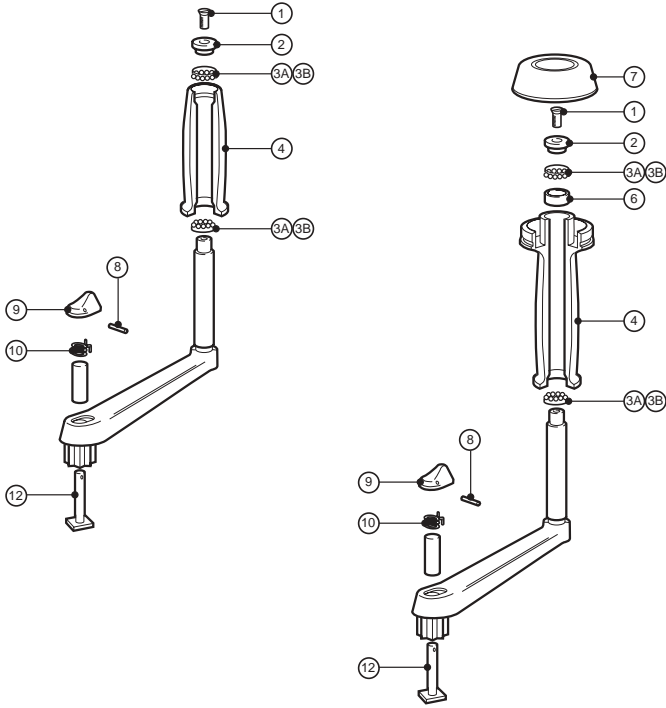

Regular Turn Spares

Item	Description	Part Number	No.off
1	M5 x 16 Screw	B4281	1
2	Spindle Cap	15100005G	1
3a	3/16" S/S Ball	B1653	16
3b	Ball Bearing Cage	15100004	2
4	Handle Turn	15100006G	1
	FULL KIT	29140011	1

Power Grip Turn Spares

Item	Description	Part Number	No.off
1	M5 x 16 Screw	B4281	1
2	Spindle Cap	15100005G	1
3a	3/16" S/S Ball	B1653	16
3b	Ball Bearing Cage	15100004	2
4	Handle Turn	25001871	1
6	Spacer	B5931	1
7	Grip Cap	25001876	1
	FULL KIT	29140015	1

250mm (10") Lock Lever Spares

Item	Description	Part Number	No.off
8	Spirol Pin	B1505	1
9	Lock Lever	18100007G	1
10	Lock Spring	15100013	1
11	Sleeve	15100030	1
12	Lock-in Sub Assembly	18100010	1
	FULL KIT	291740013	1

250MM (10") DOUBLE TURN WINCH HANDLE SPARES

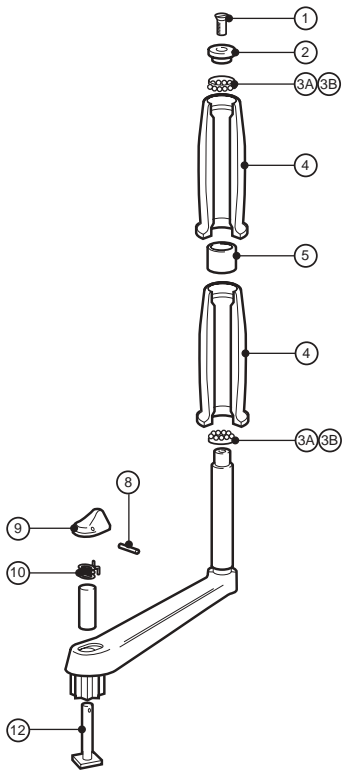

Double Turn Spares Full Kit

Item	Description	Part Number	No.off
1	M5 x 16 Screw	B4281	1
2	Spindle Cap	15100005G	1
3a	3/16" S/S Ball	B1653	16
3b	Ball Bearing Cage	15100004	2
4	Handle Turn	15100006G	1
5	Bush	15100016	1

250mm (10") Lock Lever Spares

Item	Description	Part Number	No.off
8	Spirol Pin	B1505	1
9	Lock Lever	18100007G	1
10	Lock Spring	15100013	1
11	Sleeve	15100019	1
12	Lock-in Sub Assembly	18100001	1
	FULL KIT	291740013	1

SALES OFFICES

Lewmar UK

Lewmar Ltd., Southmoor Lane, Havant, Hampshire, PO9 1JJ, UK
tel +44 (0)23 92 471841 **fax** +44 (0)23 92 485720
e-mail info@uk.lewmar.com

Lewmar Americas

Lewmar Inc., New Whitfield Street, Guilford, CT 06437, USA
tel +1 203 458 6200 **fax** +1 203 453 5669
e-mail info@usa.lewmar.com

Lewmar Southern Europe (France)

Lewmar Ltd., Place Bernard Moitessier, 17000 La Rochelle, France
tel +33 (0) 5 46 50 50 46 **fax** +33 (0) 5 46 50 59 04
e-mail info@france.lewmar.com

Lewmar Southern Europe (France)

Lewmar Ltd., Allée Charles Nungesser,
Parc D'Activités de la Siagne 06210 Mandelieu, France
tel +33 (0) 4 93 48 80 48 **fax** +33 (0) 4 93 48 37 50
e-mail info@france.lewmar.com

Lewmar Sothern Europe (Italy)

Lewmar Ltd., Place Bernard Moitessier, 17000 La Rochelle, France
tel +39 (0) 5 43 84 691 **fax** +39 (0) 5 43 84 691
e-mail info@italy.lewmar.com

Lewmar Southern Europe (Spain)

Lewmar Ltd., Sucursal en Espana, Joan de Borbó 92,
08039 Barcelona, Spain
tel +34 (0) 93 221 94 37 **fax** +34 (0) 93 225 19 49
e-mail info@spain.lewmar.com

Lewmar Northern Europe (Sweden)

Lewmar Marin AB, Hällefjordregatan 24, S-426 58,
Västra Frölunda, Sweden
tel +46 (0) 31 769 7700 **fax** +46 (0) 31 769 7710
e-mail info@sweden.lewmar.com

Lewmar Northern Europe (Finland)

Lewmar Marin AB (Finland), Laaksotie 10 A-B,
02700 Kauniainen, Finland
tel +358 (0) 9 5489 5110 **fax** +358 (0) 9 5489 5111
e-mail info@finland.lewmar.com

Lewmar Mid Europe (Netherlands)

Lewmar Mid Europe Ltd., Popovstraat 12, 8013 RK Zwolle, Netherlands
tel +31 (0) 38 427 34 90 **fax** +31 (0) 38 421 56 42
e-mail info@holland.lewmar.com

Lewmar Pacific Rim, Asia & Middle East

Lewmar Pty Ltd., 35 Leander Street, Chapel Hill,
Queensland 4069, Australia
tel +61 7 3720 2261 **fax** +61 7 3720 2263
e-mail info@lewmar.com.au

LEWMAR®

HEAD OFFICE

LEWMAR LIMITED

Southmoor Lane, Havant, Hampshire, PO9 1JJ, UK
tel +44 (0) 23 92 471841 **fax** +44 (0) 23 92 485720
e-mail info@lewmar.com
website www.lewmar.com